

Numerical Missile Impact Analyses on Concrete Containment Buildings of Nuclear Power Plants: Review and Recent Progress



Oliver Martin

(oliver.martin@jrc.nl)

Joint Research Centre (JRC)

IE - Institute for Energy

Petten - The Netherlands

<http://ie.jrc.ec.europa.eu/>

- Missile Impact Analysis & Testing on Concrete Containment Buildings of Nuclear Power Plants (NPPs) - Overview
- OECD-NEA Benchmark Project IRIS
- Modelling Approach & Computational Results

Missile Impact Analysis & Testing on Concrete Containment Buildings of Nuclear Power Plants

-

Overview

First considerations made in the 1970s when most of today's operating NPPs were built.

➤ **Missile Impact Tests**

- Large Scale Tests (Meppen Slab Tests, Tests at Sandia, ...)
- Lab Scale Tests (Tests by CEA/EDF, ...)

➤ **Computational Analyses**

- Empirical Formulas (mostly for assessing penetration depth)
- Finite Difference and Finite Element Approaches
 - With load curve (Riera Method)
 - Complete numerical models including mesh for missile

Meshes used in early numerical models were coarse.

Principle: Impact of Missile on Containment Structure simulated by Load Curve (resembling Contact Force)

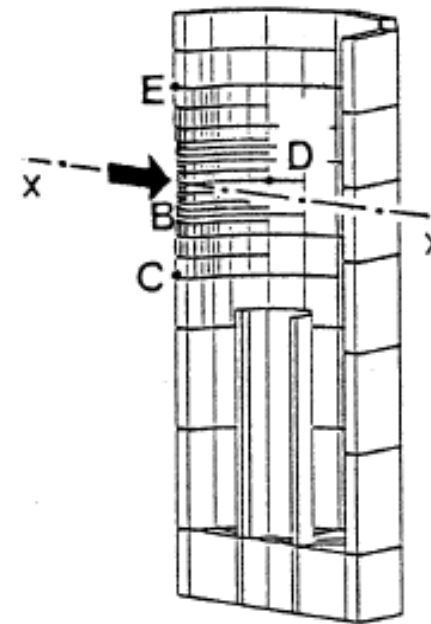
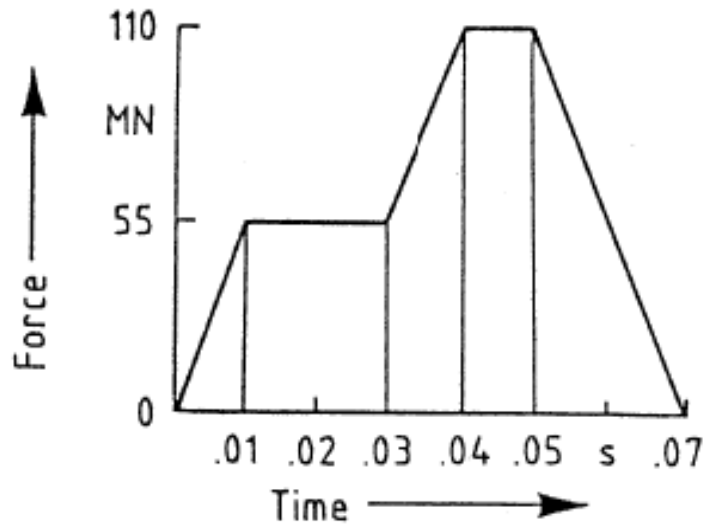

- Advantage: No contact modelling required allowing numerically stable analyses (Asset in 1970s because of limited hardware capacities)
- Disadvantage: Impact Effects on Missile cannot be assessed.

Riera Method is still used extensively today, especially for analyses involving models of complete Containment Buildings !!

Mesh representing Missile is impacted into mesh representing part of containment structure or even only a concrete slab (in-line with missile impact tests).

- Advantage: Allows Assessment of Impact Effects of Concrete Structure & Missile
- Disadvantage: Numerically stable analysis & realistic results (often still a problem today).

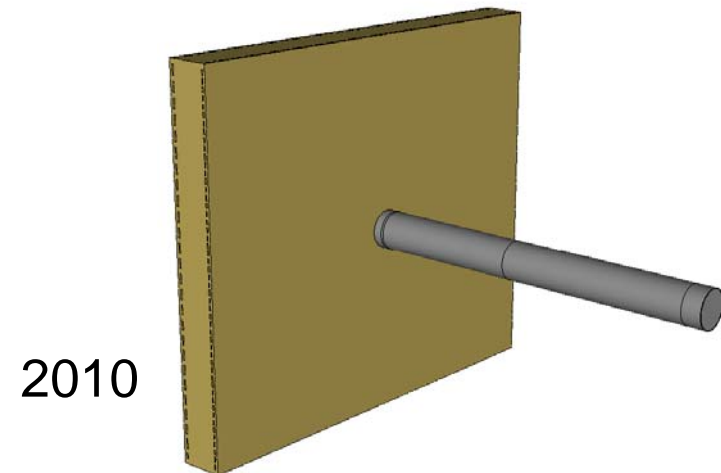
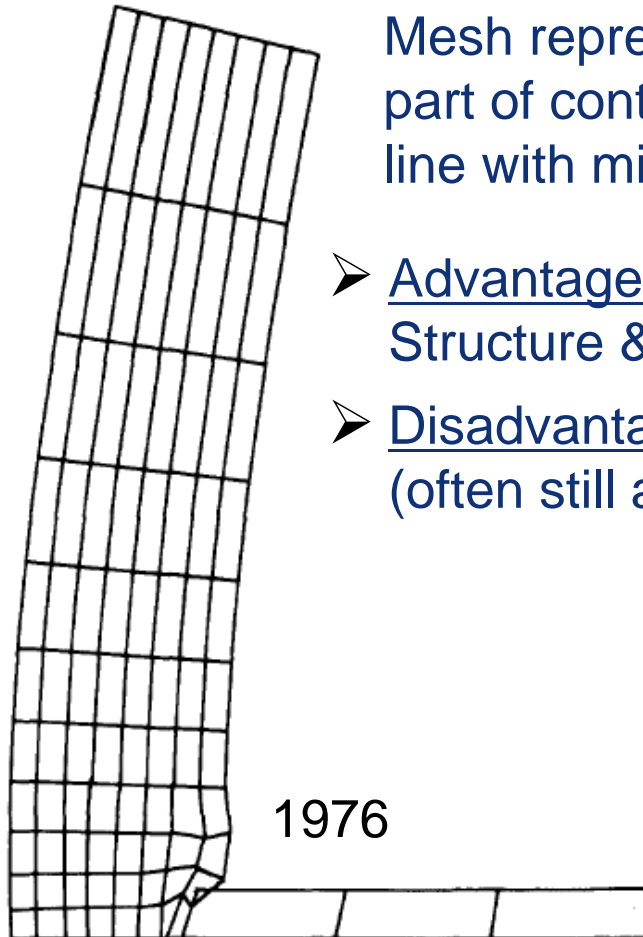

Approach with just involving a slab is still common today, but models are far more refined and often 3D !!

OECD-NEA Benchmark Project IRIS

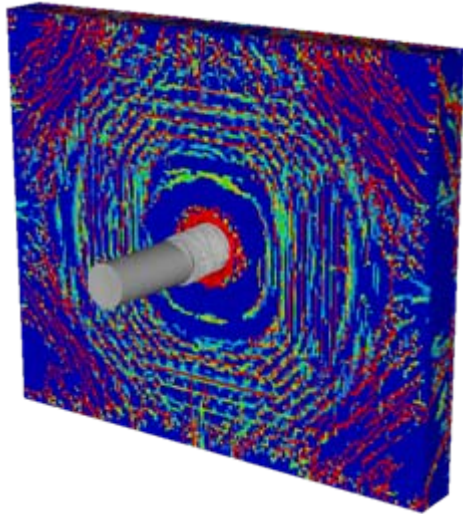

“Improving Robustness Assessment Methodologies for Structures impacted by Missiles (IRIS)”

Aim of Benchmark: To assess State-of-the-Art of Modelling of Missile Impacts on Concrete Containment Structures

Duration: 1 Year (Jan – Dec 2010)

Request: Large variety in methods (FE, Finite Difference), modelling approaches & solvers (ABAQUS/Explicit, LS-Dyna3D, ...) desired !!

Wide Participation of nuclear Organisations (25 organisations):

- Tractebel (B)
- AECL, CNSC (CA)
- NRI Rez (CZ)
- Stuk, VTT (FI)
- CEA, EDF, IRSN (F)
- Areva NPP GmbH, GRS (D)
- KINS (KOR)
- JNES (J)
- NRA (SK)
- Sandia National Laboratories (USA)
- JRC**, Fusion for Energy (EU)
- ...

Numerical Analyses are performed on 3 Tests:

- **VTT-IRSN Flexural Test (new)**
- **VTT-CNSC-IRSN Punching Shear Test (new)**
- **Meppen-II-4 Test (late 1970s, flexural test)**

Test results are distributed to benchmark participants by 3rd November 2010 to assess quality of their numerical analyses.

Caused by elastic-plastic response

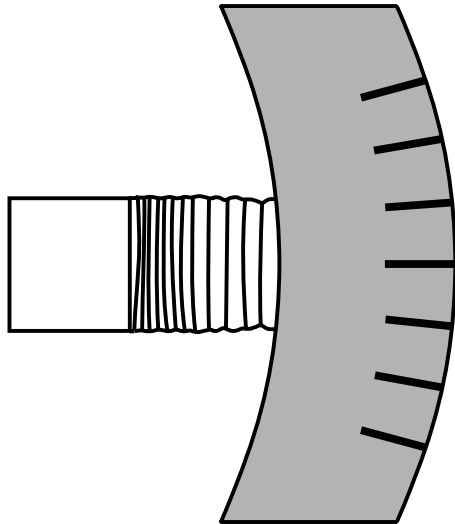

Flexural Failure

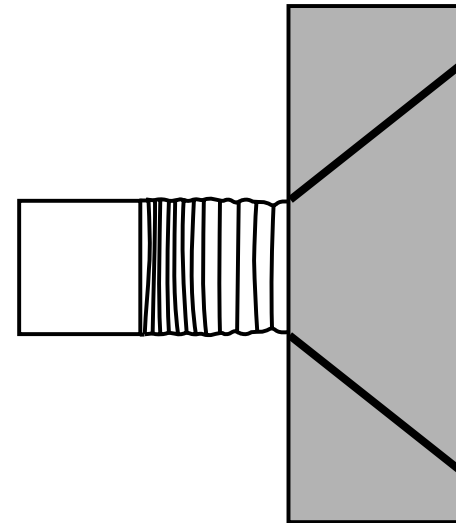

Punching Shear Failure

Caused by stress wave response

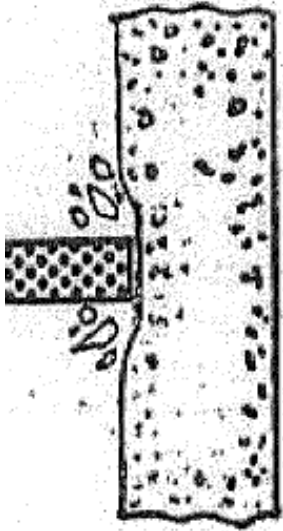

Surface Failure

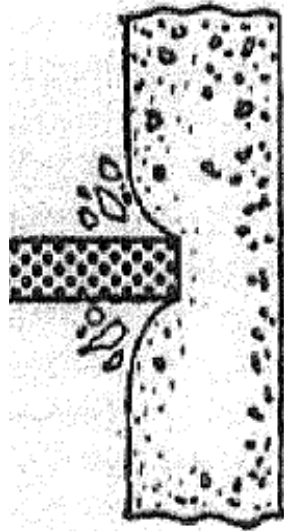

Spalling

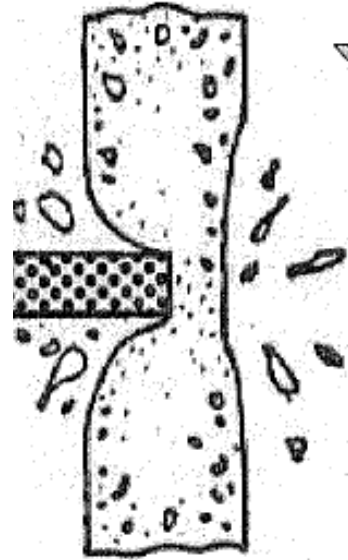

Scabbing

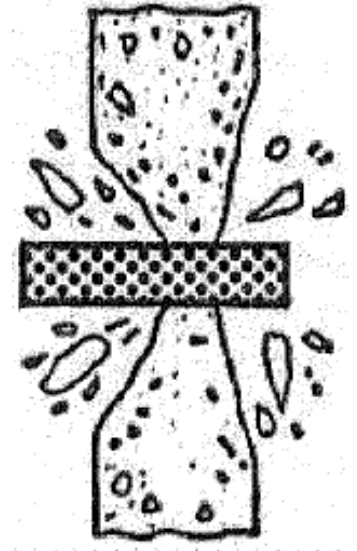

Perforation

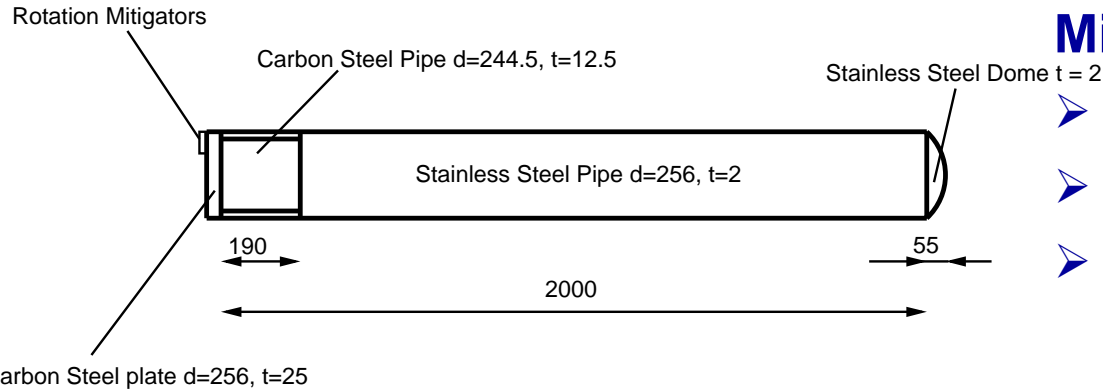

Missile Characteristics (soft missile):

- Thin stainless steel pipe & dome
- Thick carbon steel pipe & plate at rear
- $m=50$ kg, $v=110$ m/s

Slab Characteristics:

- Dimensions: $2.1\text{m} \times 2.1\text{m} \times 0.15\text{m}$
- Reinforcement front: ϕ 6mm, $5\text{cm}^2/\text{m}$
- Reinforcement back: ϕ 6mm, $5\text{cm}^2/\text{m}$
- Transverse reinforcement: ϕ 6mm, $50\text{cm}^2/\text{m}^2$
- Simply supported along 4 edges in supporting frame

Supporting frame

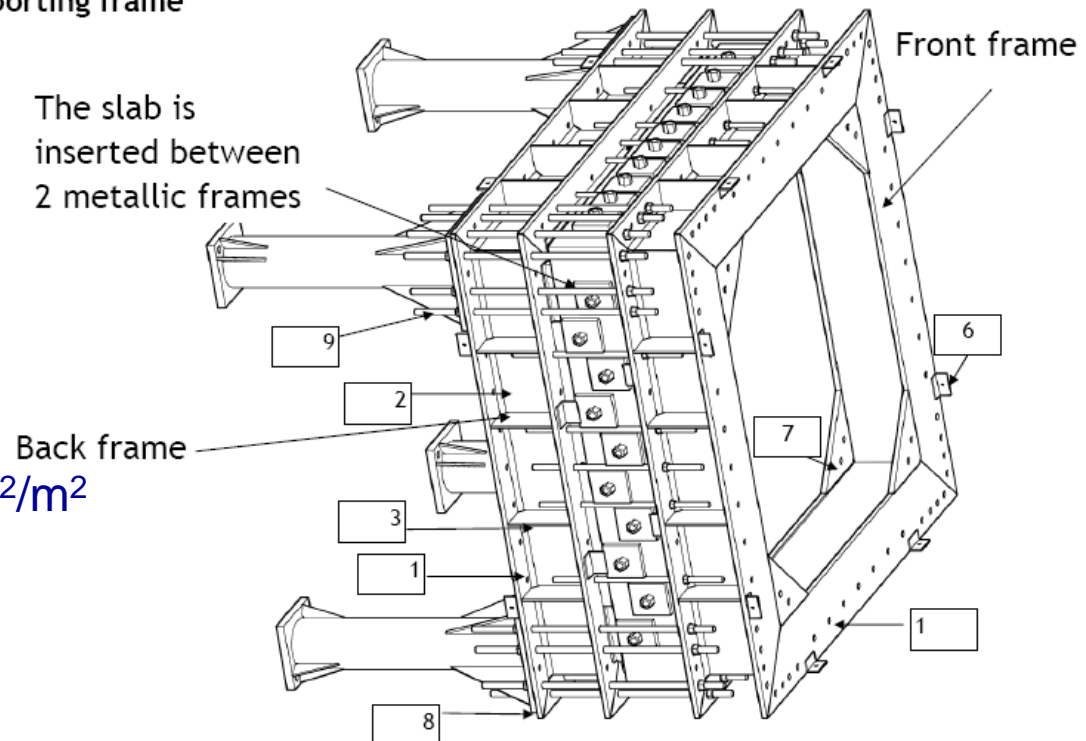

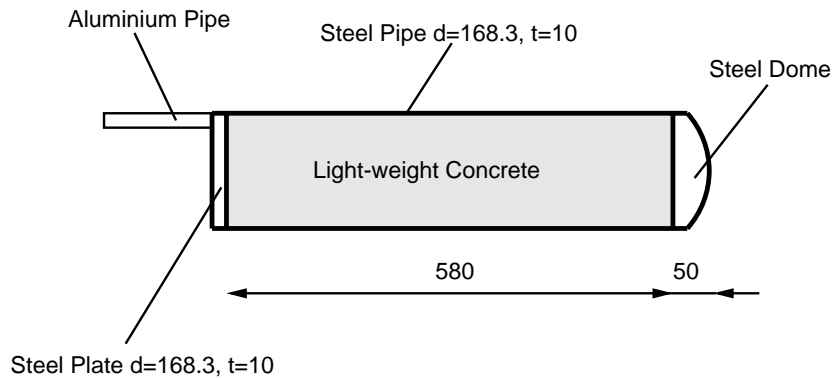

Missile Characteristics (hard missile):

- steel pipe filled with light-weight concrete
- Stiff & heavy steel dome at front
- Thick steel plate at rear
- $m=47 \text{ kg}$, $v=135 \text{ m/s}$

Slab Characteristics:

- Dimensions: $2.1\text{m} \times 2.1\text{m} \times 0.25 \text{ m}$
- Reinforcement front: $\phi 10\text{mm}$, $8.7\text{cm}^2/\text{m}$
- Reinforcement back: $\phi 10\text{mm}$, $8.7\text{cm}^2/\text{m}$
- No transverse reinforcement
- Simply supported along 4 edges in supporting frame

Supporting frame

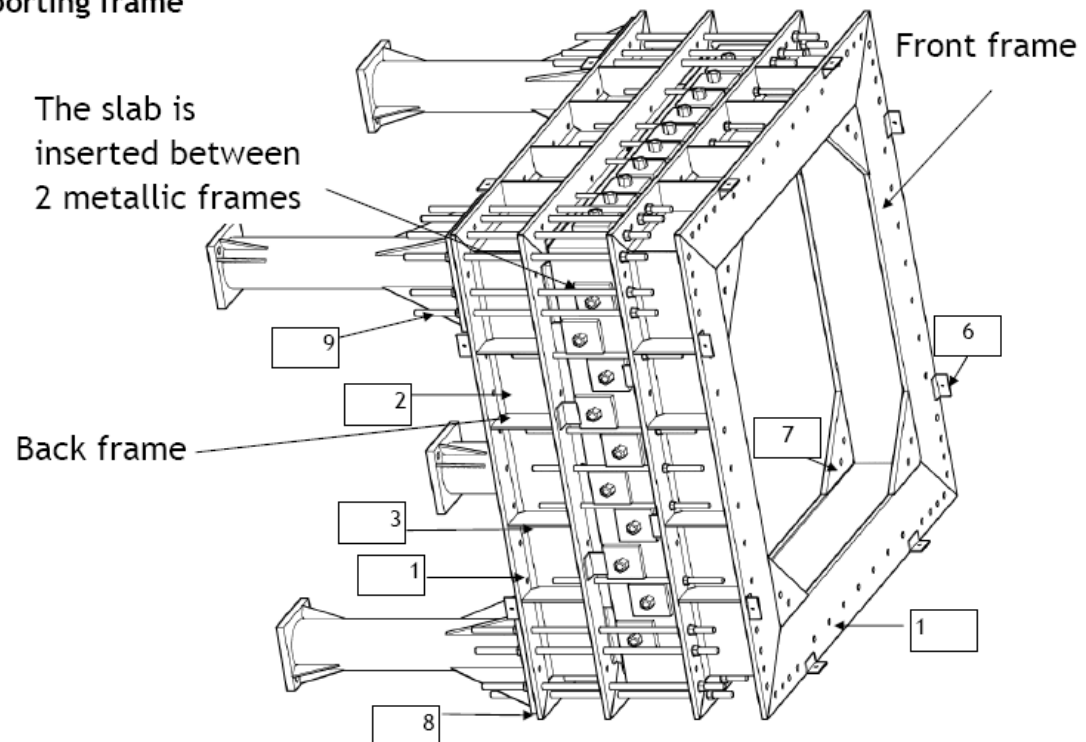

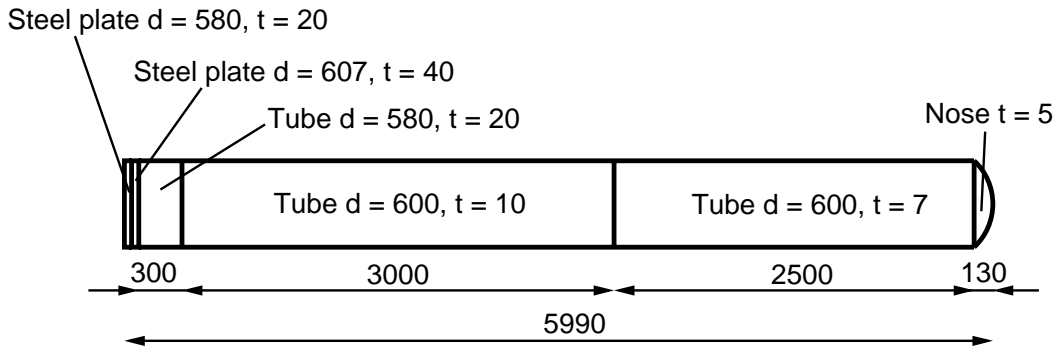

Missile Characteristics (soft missile):

- Thin carbon steel pipe & dome
- Thick carbon steel plates at rear
- $m=1016 \text{ kg}$, $v=247.7 \text{ m/s}$

Slab Characteristics:

- Dimensions: $6.5\text{m} \times 6\text{m} \times 0.7 \text{ m}$
- Reinforcement front: $\phi 20\text{mm}$, $27.3\text{cm}^2/\text{m}$
- Reinforcement back: $\phi 28\text{mm}$, $53.6\text{cm}^2/\text{m}$
- Transverse reinforcement: $\phi 20\text{mm}$, $50.2\text{cm}^2/\text{m}^2$
- Supported on 48 points on its back

Meppen-II-4 Test is one test of 2nd serial (22 tests in total) of the Meppen Slab Tests performed by SIEMENS/HOCHTIEF in late 1970s / early 1980s

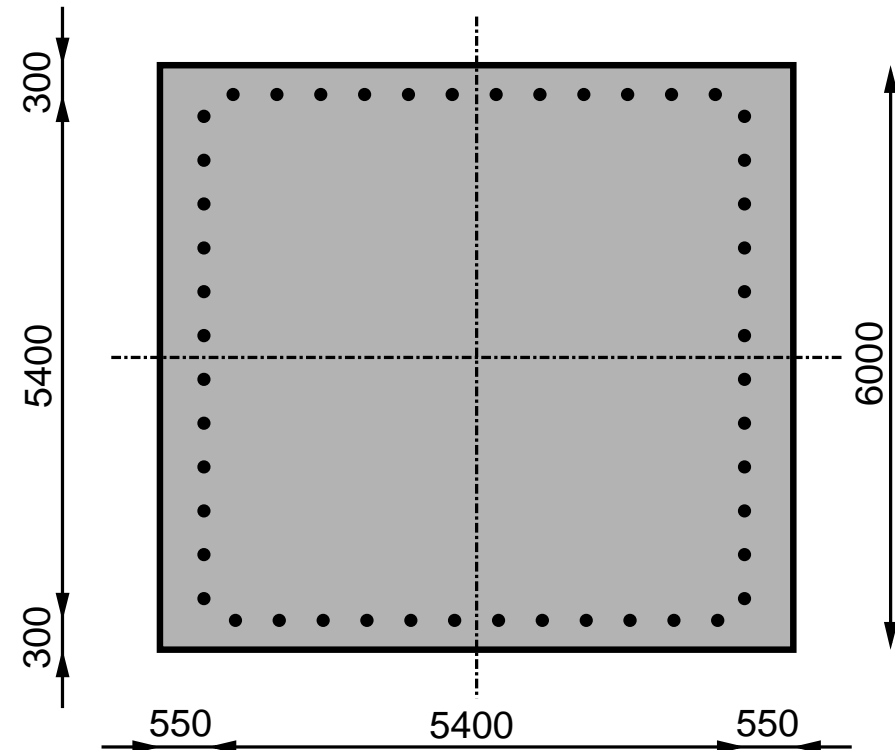

Modelling Approach & Computational Results

Contracted work to Altair Engineering France in order to

- Build-up FE Models on all 3 Tests
- Perform analyses with RADIOSS & evaluation of results afterwards

JRC then

- Transforms RADIOSS models into ABAQUS format
- Performs analyses with ABAQUS/Explicit & evaluation of results afterwards (on-going)

- 8 noded brick elements of reduced integration
- Large deformations, viscous hourglass, Co-rotational formulation
- Constitutive Model of Han & Chen (1984, RADIOSS Material Law No. 24)

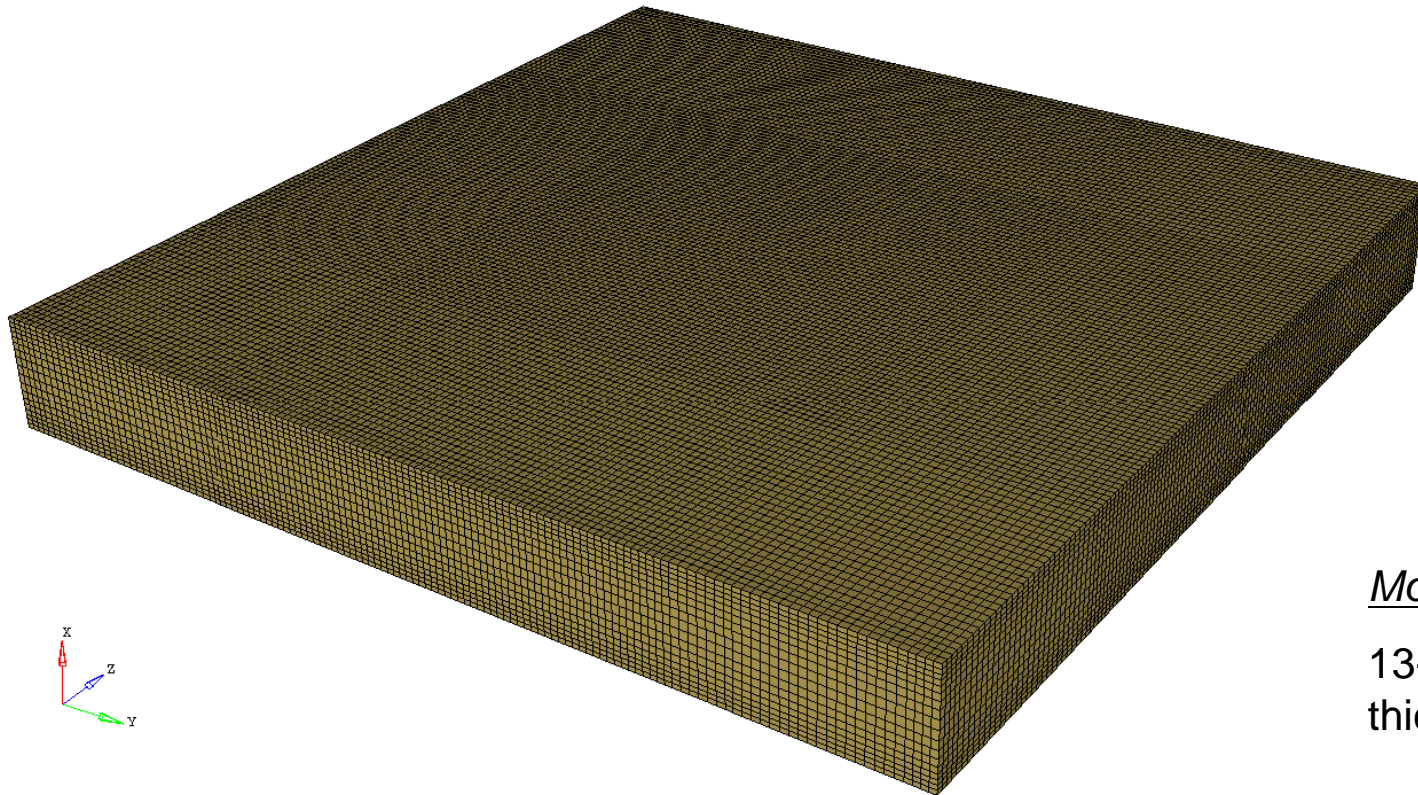

Modeling Hint:

13-22 elements in slab thickness.

- Type: Drucker-Prager/Cap Model
- Standard constitutive model in RADIOSS for pre-stressed concrete (Material Law No. 24)

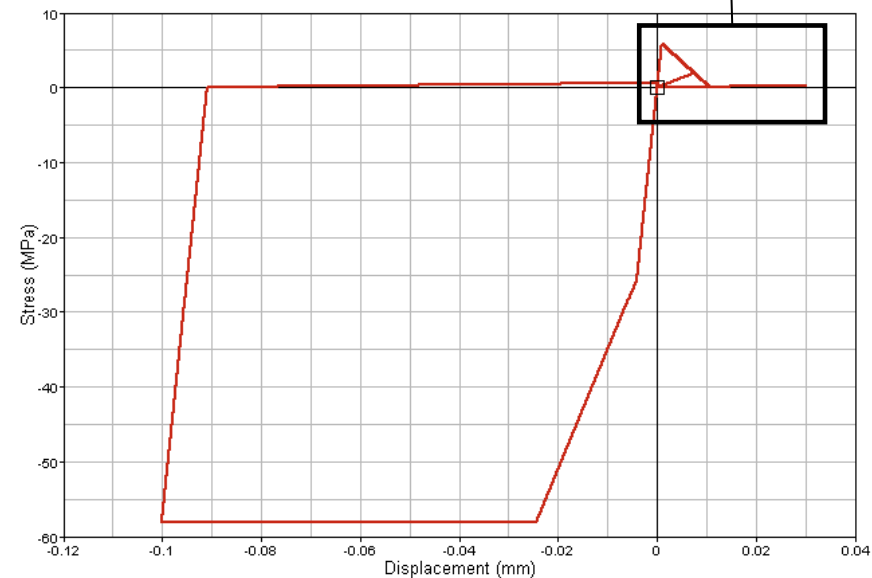
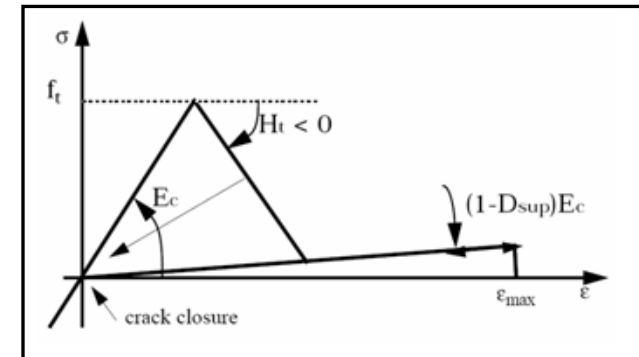
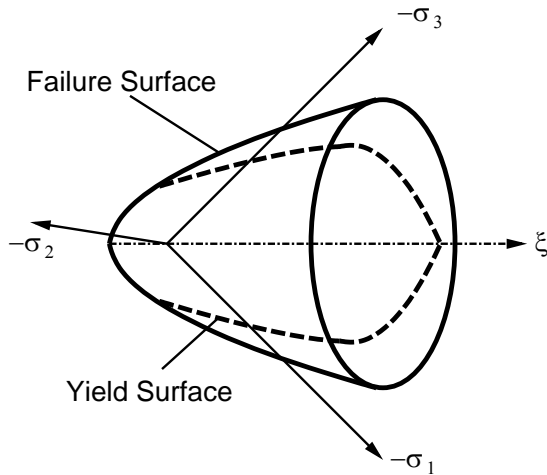

Calibration of material model according to basic material properties distributed to benchmark participants

- Linear Beam Elements
- Proper inertia and cross section definition
- Nodes of beam elements are merged with nodes of brick elements for the concrete
- Johnson-Cook Model with strain-rate effects

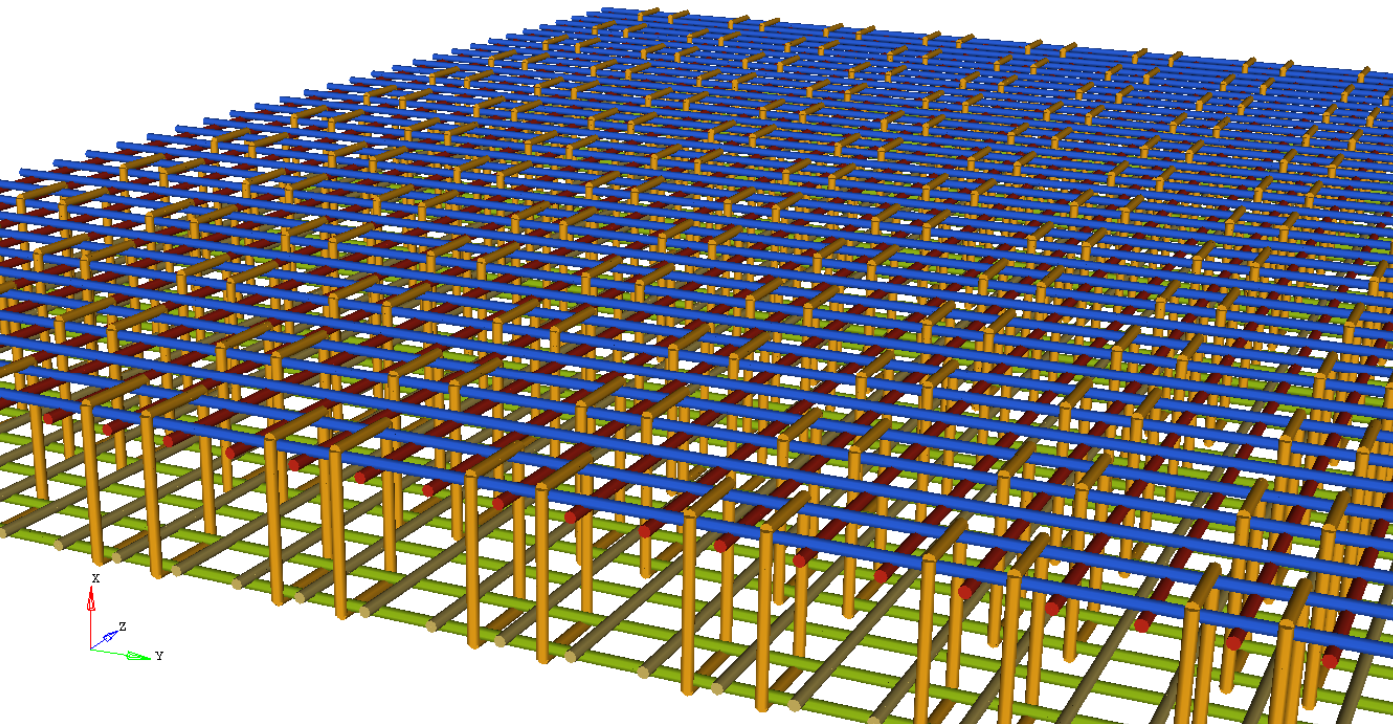

- Shell elements and/or brick elements of reduced integration
- Hourglass physical stabilization
- Material Model: Johnson-Cook model or tabular function with strain-rate effects where needed

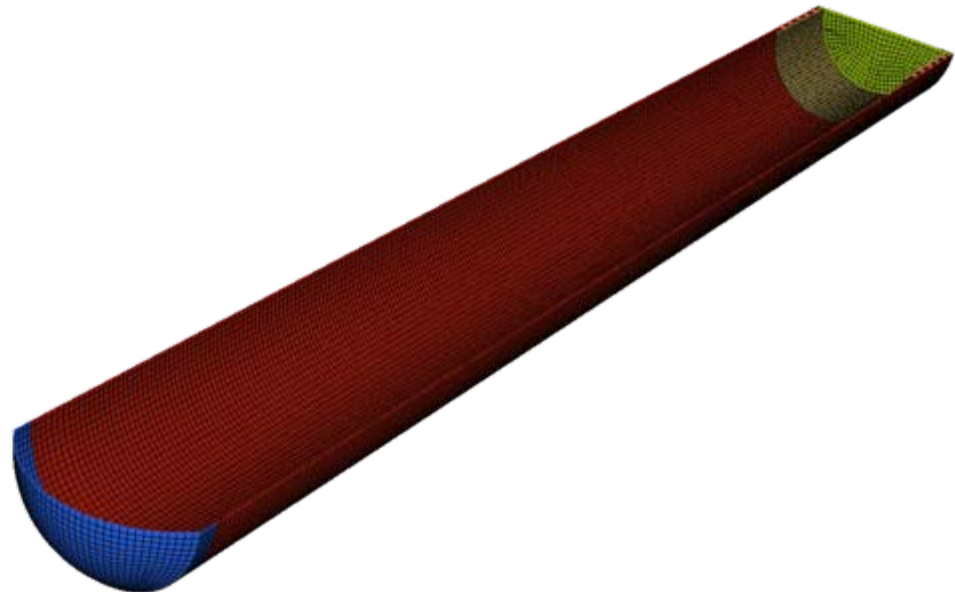
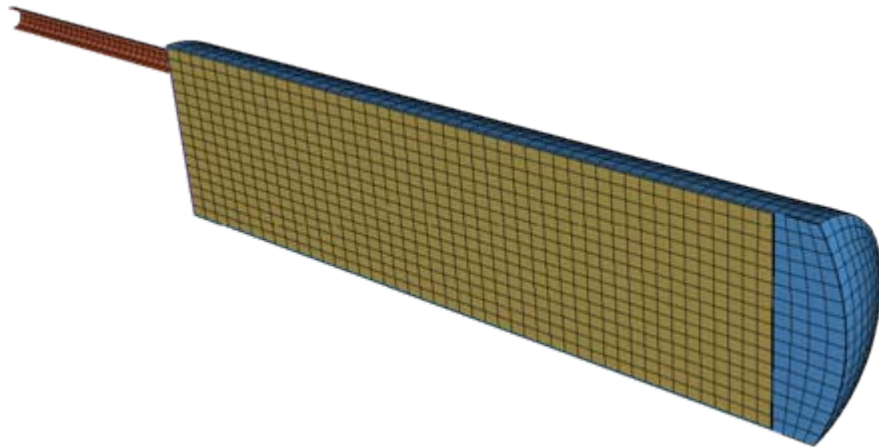

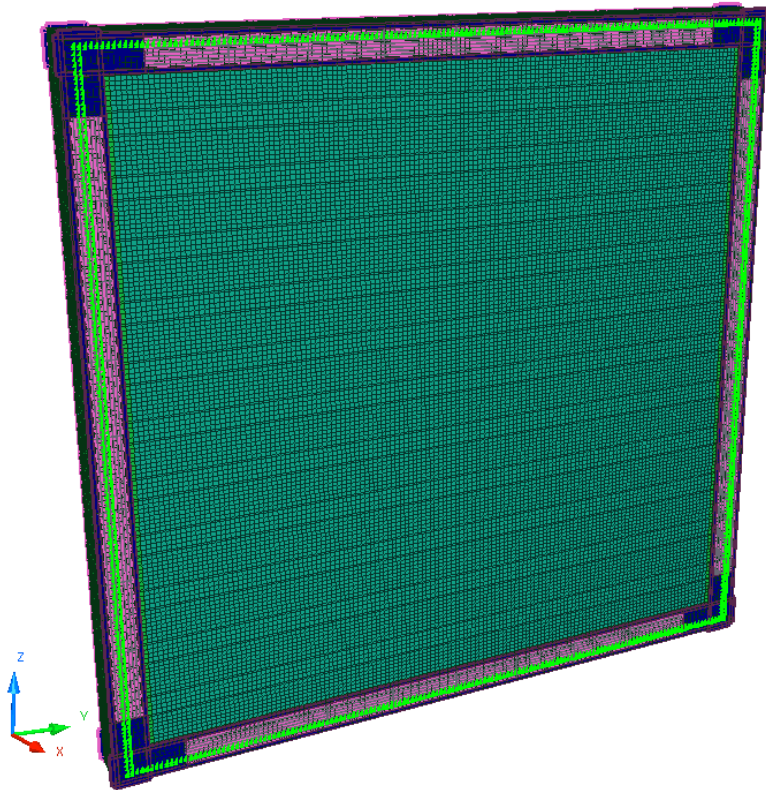

Slab Mesh Properties:

- 351728 brick element, 35384 beam elements, 383418 nodes
- Average element size: 15mm; 13 elements in slab thickness
- Concrete Material properties: $\rho=2280 \text{ kg/m}^3$, $E=26915 \text{ MPa}$, $\nu=0.2$, $F_c = 67.3 \text{ MPa}$, $F_t=6.37 \text{ MPa}$, $H_T=-1400 \text{ MPa}$
- Rebar Material Properties: $\rho=7.8 \text{ t/m}^3$, $E=203000 \text{ MPa}$, $\nu=0.3$, $R_e = 598 \text{ MPa}$, $\sigma_{\max} = 670 \text{ MPa}$

Missile Mesh Properties:

- 29820 elements, 29934 nodes
- Average element size: 8mm
- Material Properties: $\rho=7.8 \text{ t/m}^3$, $E=205000 \text{ MPa}$, $\nu=0.3$, $R_e = 220 \text{ MPa}$, $\sigma_{\max} = 500 \text{ MPa}$



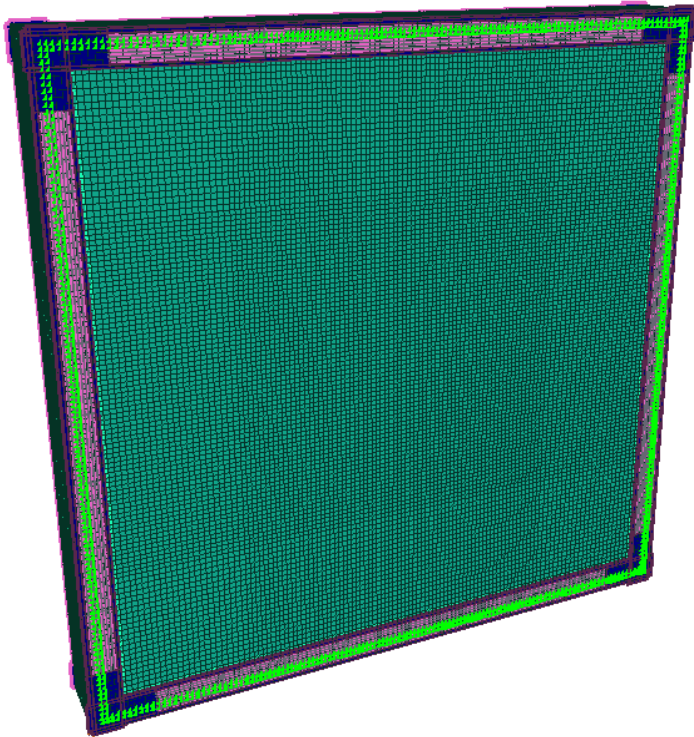

Slab Mesh Properties:

- 304200 brick element, 11776 beam elements, 326059 nodes
- Average element size: 15mm; 18 elements in slab thickness
- Concrete Material properties: $\rho=2.28 \text{ t/m}^3$, $E=29429 \text{ MPa}$, $\nu=0.2$, $F_c = 74.6 \text{ MPa}$, $F_t=7.46 \text{ MPa}$, $H_T=-1000 \text{ MPa}$
- Rebar Material Properties: $\rho=7.8 \text{ t/m}^3$, $E=203000 \text{ MPa}$, $\nu=0.3$, $R_e = 598 \text{ MPa}$, $\sigma_{\max} = 670 \text{ MPa}$

Missile Mesh Properties:

- 11760 brick elements, 2796 shell elements, 16252 nodes
- Average element size: 11mm
- Material Properties Steel: $\rho=7.8 \text{ t/m}^3$, $E=205000 \text{ MPa}$, $\nu=0.3$, $R_e = 355 \text{ MPa}$, $\sigma_{\max} = 555 \text{ MPa}$
- Material Properties Concrete: like slab except $\rho=1.4 \text{ t/m}^3$

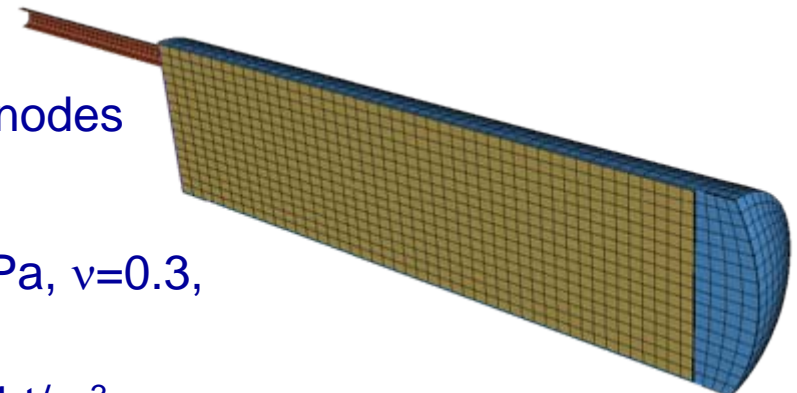

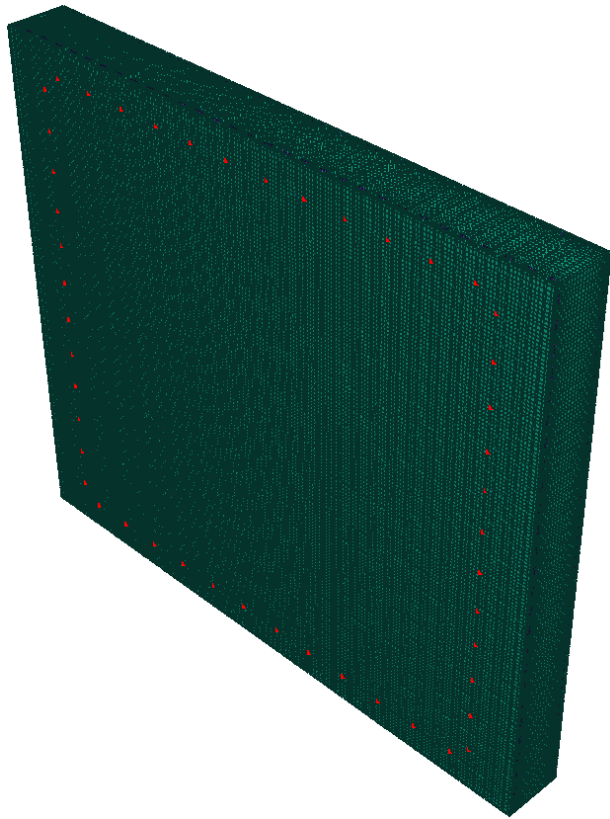

Slab Mesh Properties:

- 727584 brick element, 61440 beam elements, 769143 nodes
- Average element size: 35mm; 22 elements in slab thickness
- Concrete Material properties: $\rho=2.37 \text{ t/m}^3$, $E=29053 \text{ MPa}$, $\nu=0.2$, $F_c = 37.2 \text{ MPa}$, $F_t=4.8 \text{ MPa}$, $H_T=-3000 \text{ MPa}$
- Rebar Material Properties: $\rho=7.8 \text{ t/m}^3$, $E=210000 \text{ MPa}$, $\nu=0.3$, $R_e = 430 \text{ MPa}$, $\sigma_{\max} = 624 \text{ MPa}$

Missile Mesh Properties:

- 30132 elements, 30038 nodes
- Average element size: 20mm
- Material Properties: $\rho=9.1 \text{ t/m}^3$, $E=210000 \text{ MPa}$, $\nu=0.3$, $R_e = 286 \text{ MPa}$, $\sigma_{\max} = 411 \text{ MPa}$

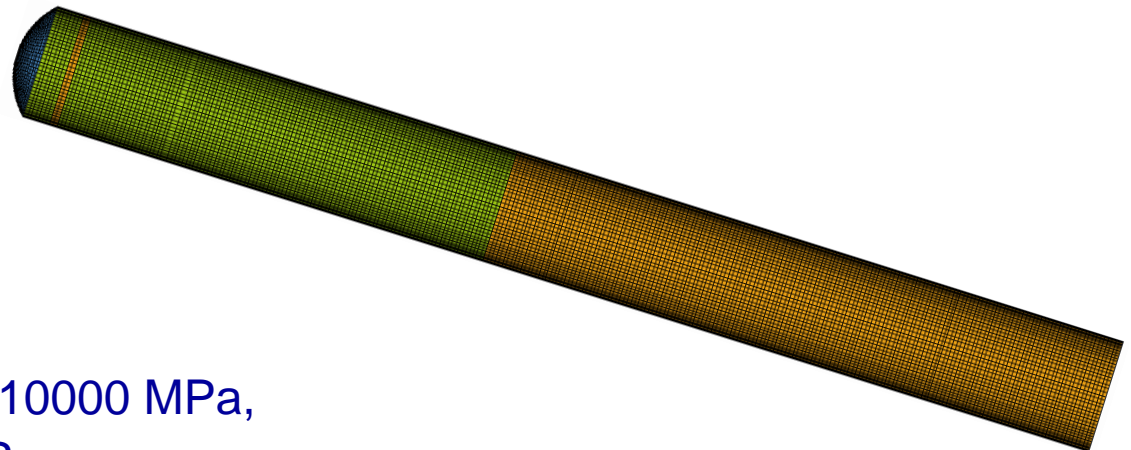

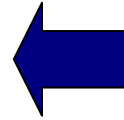
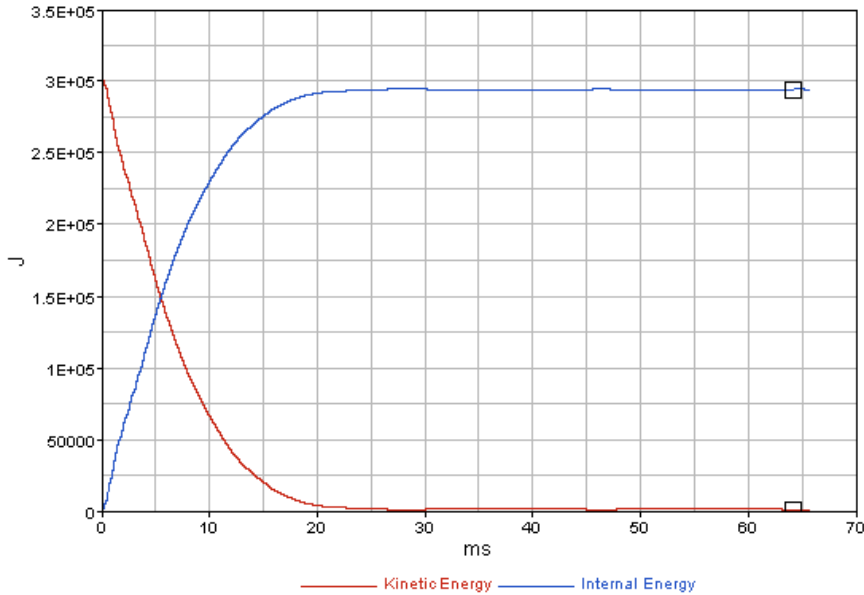

All initial kinetic energy of missile is transformed into deformation energy

Contact force between missile and slab scatters in beginning and then stabilizes & decreases to zero

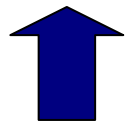
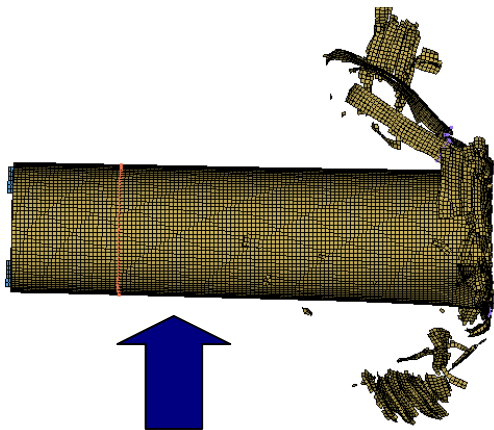
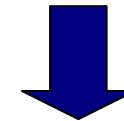

50% of initial length of Missile crumbles away.

Load time history between the missile and the target

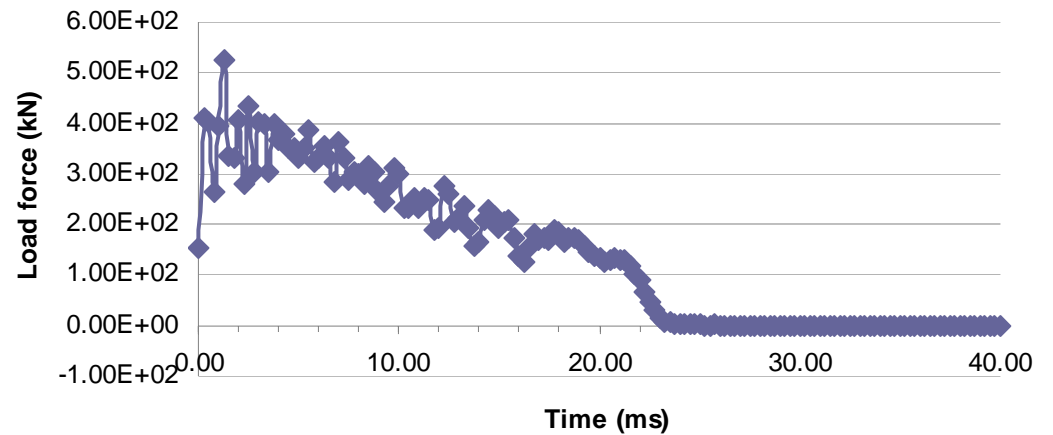

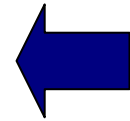
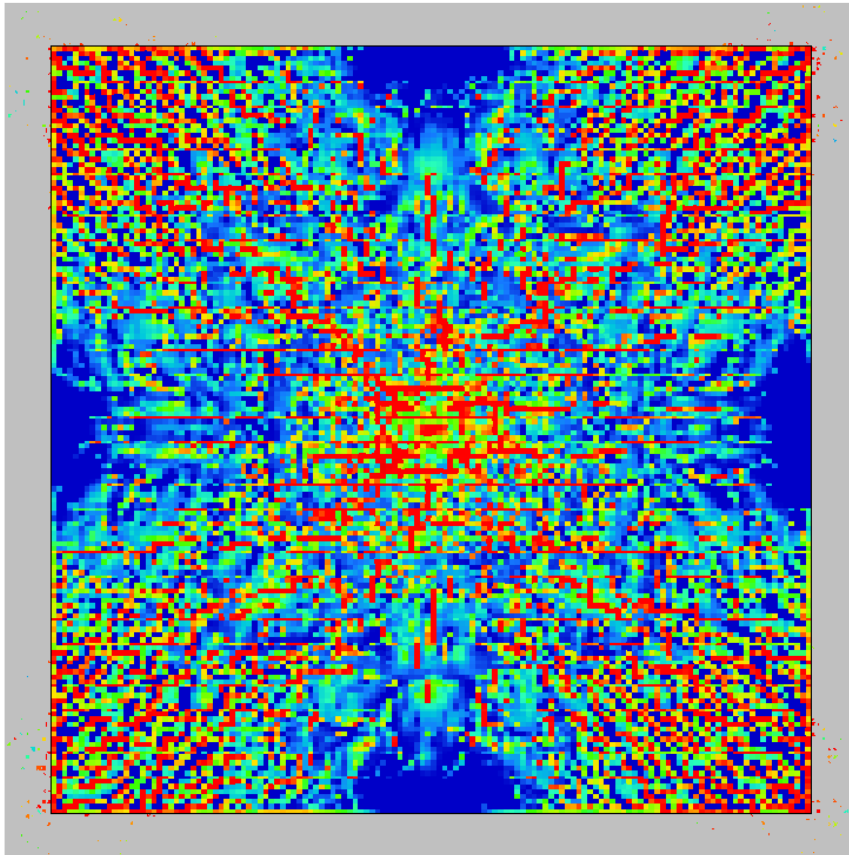

Typical crack pattern of flexural test

Slab vibrates due to impact.

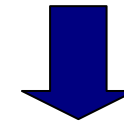

Displacement time histories at the rear of the slab
: w1

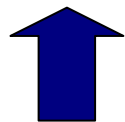
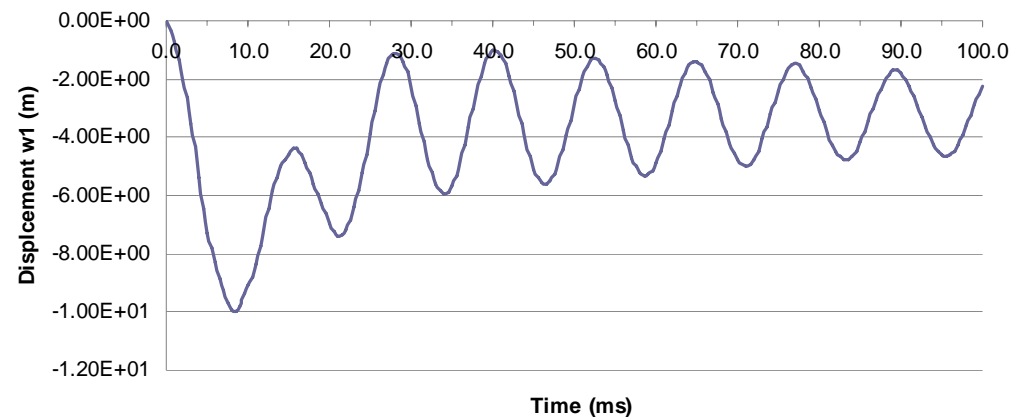

Shear cone formed and slab bended slightly

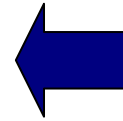
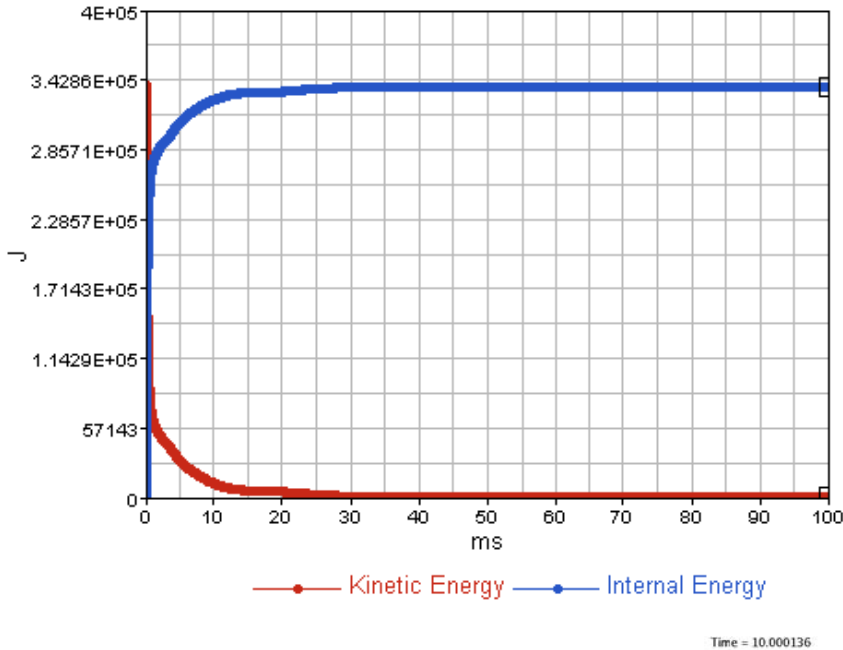

All initial kinetic energy of missile is transformed into deformation energy rather quickly (hard contact)

Contact force between missile and slab shows no scatter in beginning and decreases quickly to zero

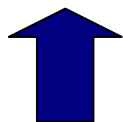
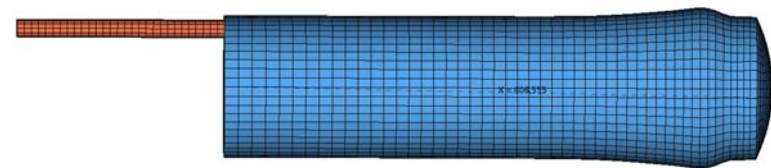
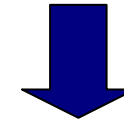

Missile shows only little deformation.

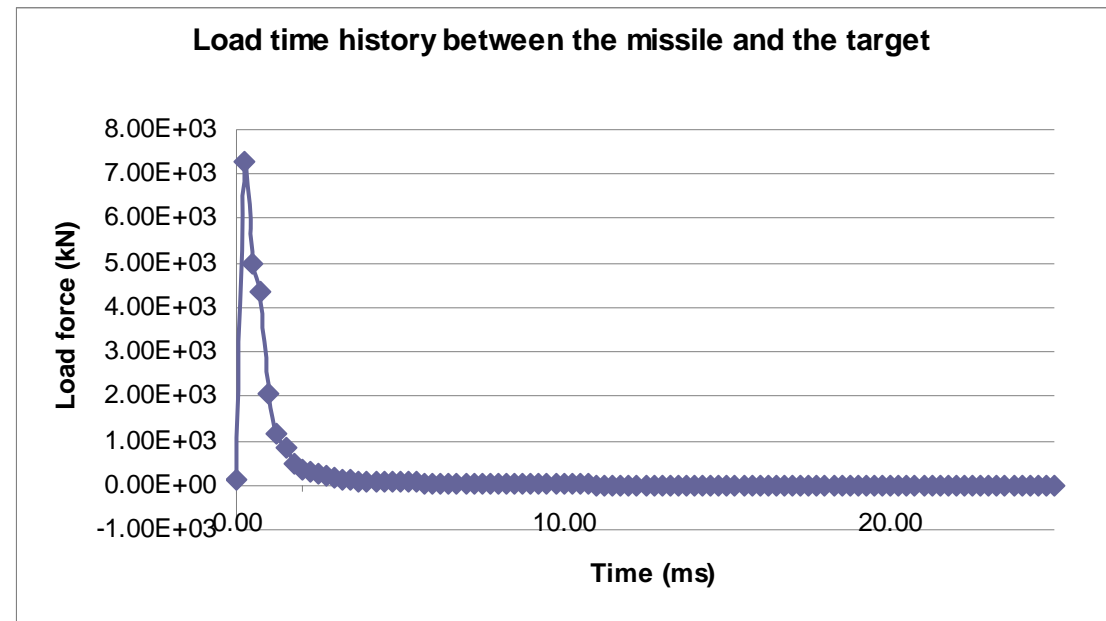

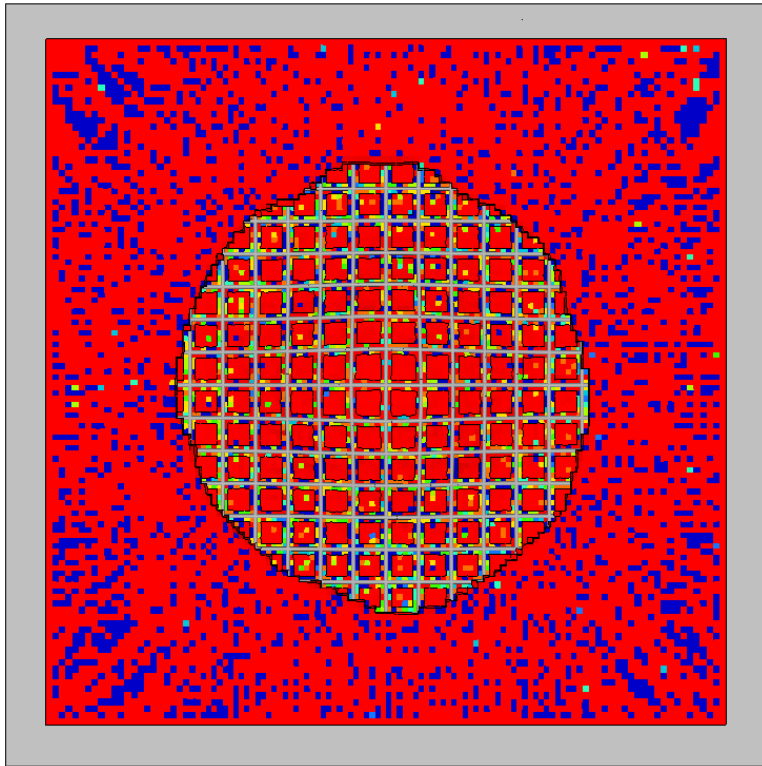

← Scabbing

Only little vibrations of slab

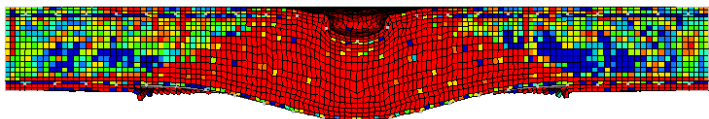
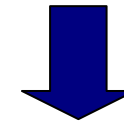

Shear cone formed and large residual deflection of slab

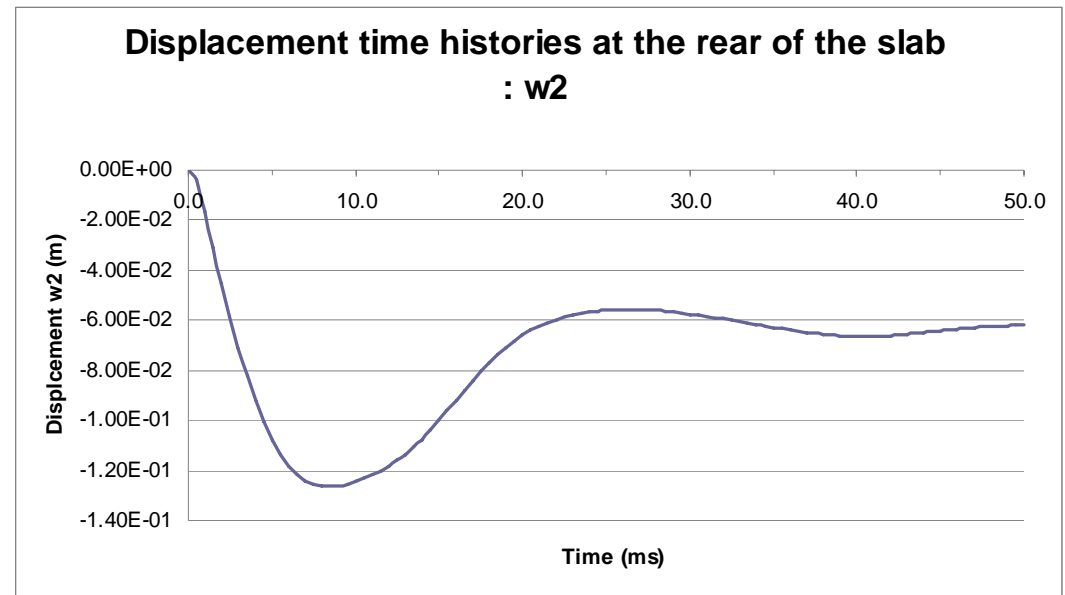

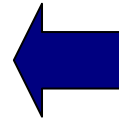
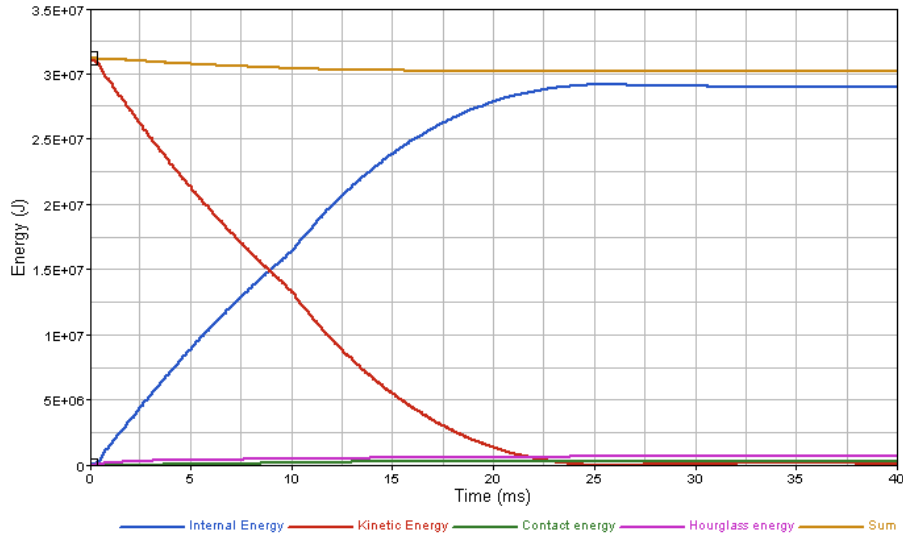

All initial kinetic energy of missile is transformed into deformation energy

Contact force between missile and slab scatters significantly in beginning and then stabilizes & decreases to zero

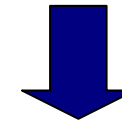

Load time history between the missile and the target

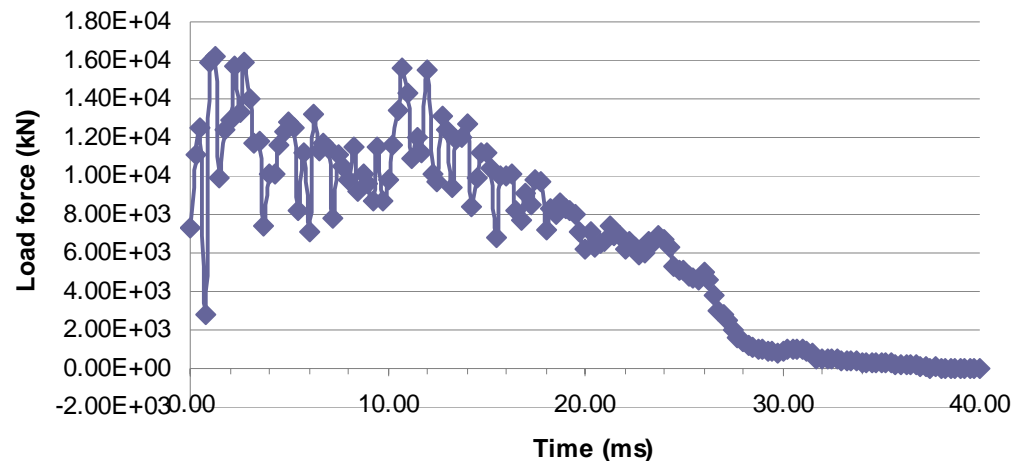

080000.35 = smt

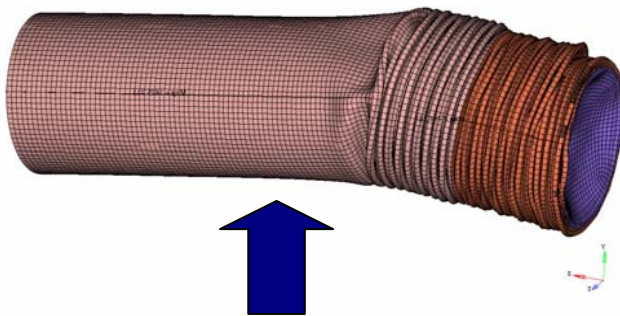

Missile compressed together by more than 50% of its initial length.

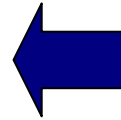
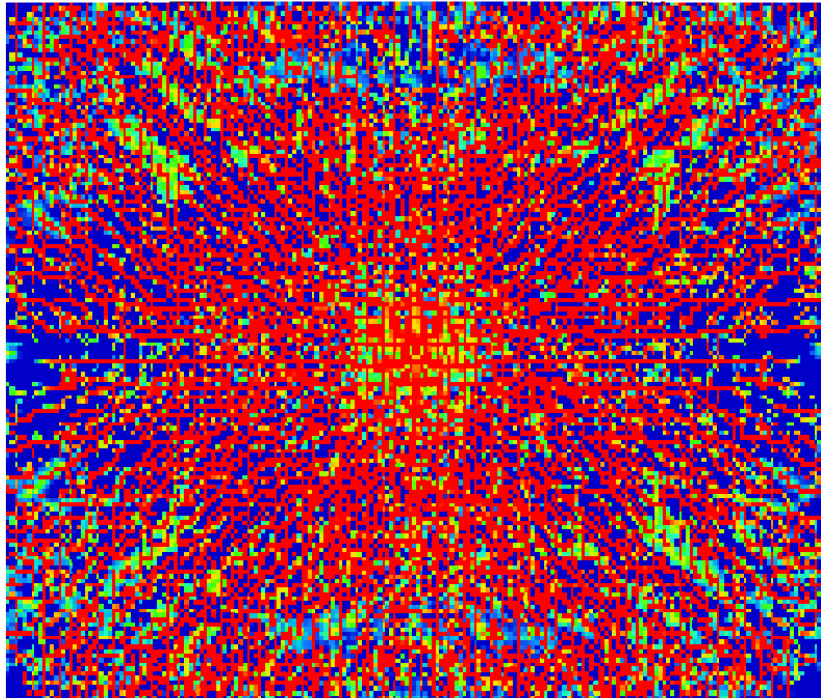

Typical crack pattern of flexural test

Slab vibrates due to impact.

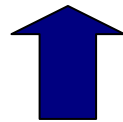
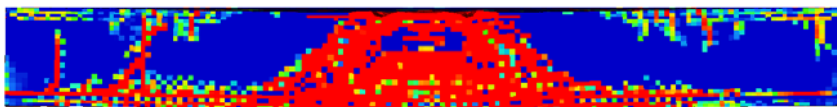
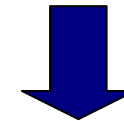

Shear cone formed and slab bended slightly

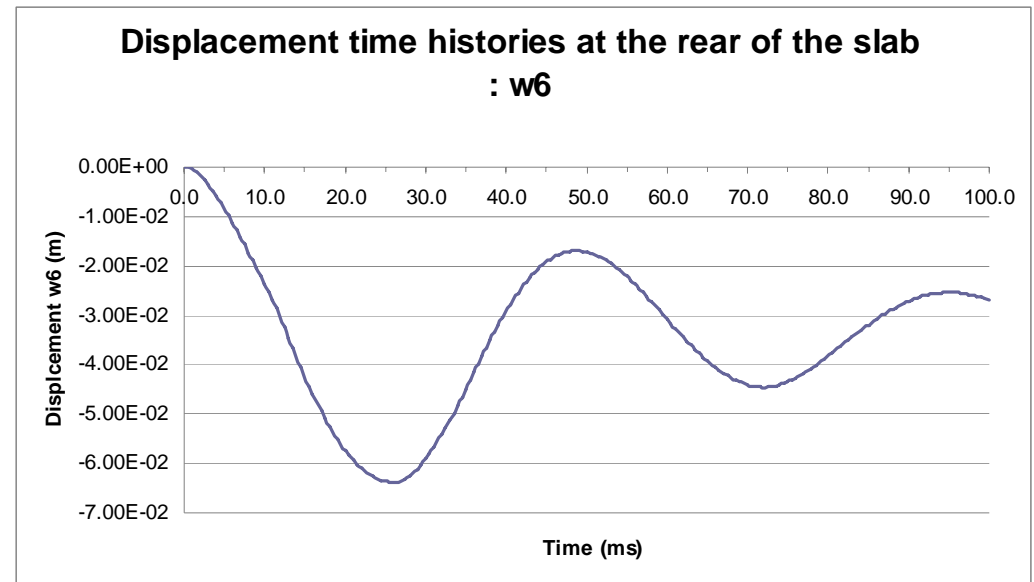

- Results of FE analyses with RADIOSS on the 3 missile impact tests are sound & resonable.
- Specific results of each analysis show expected results according to slab and missile characteristics.
- **With today's FE codes it is possible to predict the outcome of missile impact tests realistically.**

More in depth results assessment by comparison with measured time responses of deflections, rebar strains, reaction forces, etc... when they are released (next week)!!

Vincent Centro & Thierry Schwoertzig

(Altair Engineering France)

For their efforts to support EC/JRC in the IRIS Benchmark Project.

Many Thanks for your Attention

