



EADS INNOVATION WORKS

Optimization based concept development of innovative CFRP cargo-floor structures



Dipl.-Ing. Brian Bautz
Dept. TCC3/LG-SP
81663 Munich/Germany
brian.bautz@eads.com

Versailles, 28.10.2010

- Introduction cargo floor
 - Current design
 - Basic requirements
- Concept development approach
- Cargo floor concepts
 - C0 Reference concept
 - Overview of new concepts
 - C1 Cross-rib
 - C5 Corrugated sheet
- Summary

Current design and basic requirements

- Carrying of container or bulk cargo loads
- Carrying of (limited) system routings
- Standard customization without modification
- Air tightness and fire resistance
- ...

Additional requirements:

- Fail save container fixation (3 to 4 cargo tracks)



Single aisle cargo floor (baseline):

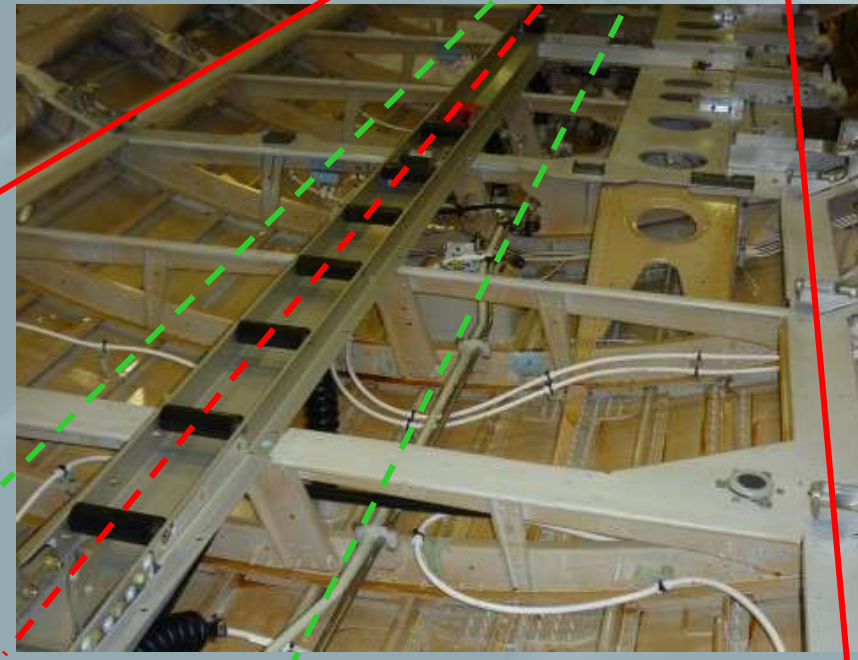

replacing of one middle track (red, dashed) by two tracks (green, dashed)

- Introduction cargo floor
 - Current design
 - Basic requirements
- **Concept development approach**
- Cargo floor concepts
 - C0 Reference concept
 - Overview of new concepts
 - C1 Cross-rib
 - C5 Corrugated sheet
- Summary

Optimisation assisted concept development What can be expected?

- Optimal results?
- New/unexpected concept?
- Objective concept comparison (in terms of weight)?
- Fast process?

Concept

Requirements:

- Geometry / designspace
- Loads
- Materials
- ...

Basic concepts I:

- Brainstorming
- ⇒ Manufacturing concepts
- ⇒ Cost effective

Basic concepts II:

- Topology optimisation
- Freesize optimisation
- ⇒ Main loadpath
- ⇒ Design proposal

Manufacturing:

- Parts/Structures
- Demonstration of manufacturing
- Test components

Design (CAD):

- Consideration of design rules
- and manufacturing concept

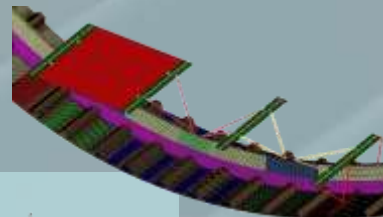
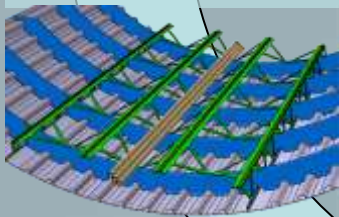

Structural optimisation:

- Size (and shape) optimisation
- Regarding strength and stability
- Consideration of manufacturing concepts
- ⇒ Dimension (and shape) of parts

Interpretation:

- ⇒ Structural concept
- ⇒ Input for sizing model

Basic model

ISSY Modell



$\begin{Bmatrix} s_{11} & s_{12} & \dots \\ s_{21} & & \dots \\ \vdots & & \ddots \end{Bmatrix} \dots$
 stiffness & load matrix

+ (MPC sewing)

fine mesh Modell

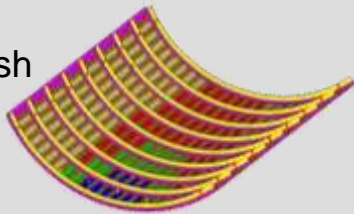

Concept components

C5:

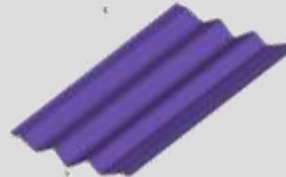

C1:



⋮

Results



⋮

Requirement for submodel technique:

- Locally limited area of interest

Req. not fulfilled by floor structure

⇒ Fine mesh model too large

⇒ Calculation times too long

⇒ Submodel technique used for final sizing

⇒ Alternative approach for basic concept development required



- Cut out of the examined aircraft part/area
- Transfer rest to stiffness and load matrix
- Fine mesh modelling of examined part/area
- Integration of concept components into fine mesh model
- Calculation with topology, size and shape optimisation
- Advantage: Consideration of global load and stiffness

Basic concept development – 1-Frame-Model

Computing time optimised model:

- Reduction of the model on one frame bay
- Coupling of free cross sections by MPCs (periodic boundary condition)
- Coupling of coarse ISSY parts by MPC-sewing
- Verification with 9-frame model and full ISSY model (good compliance)
- Multiple reduction of computing time

Basic model

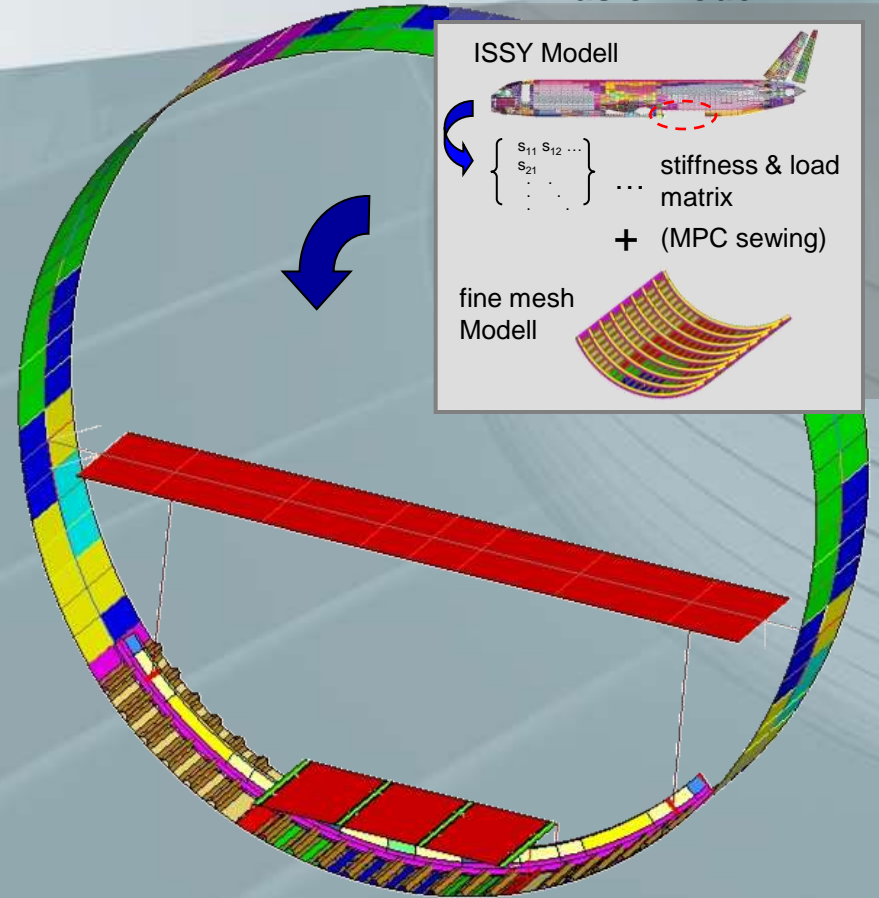
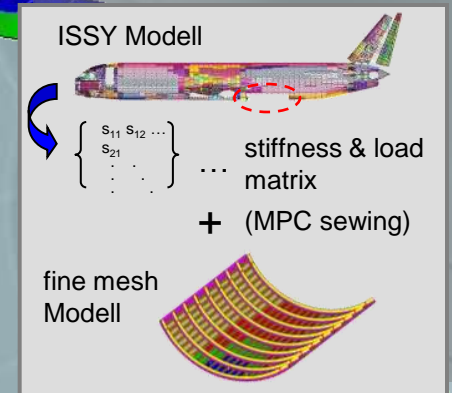

- 1-frame-model for:
Basic concept development
- Submodel technique for:
Pre- and final design of preferred concept

Loads

- Six representative loadcases (A320)
- Loads applied on corresponding cargo rail

Design criteria:

- Static strength: 0.375 % max. strain
- Buckling: linear buckling analysis;
min. eigenvalue = 1.22
- Local buckling of beam flanges: output of beam stresses
and calculation of a buckling value by HSB

Materials / Properties:

- Frame: NCF (Triax) + UD reinforcements
- Cargo floor components: QI-properties
- Min. thickness: 1,6mm

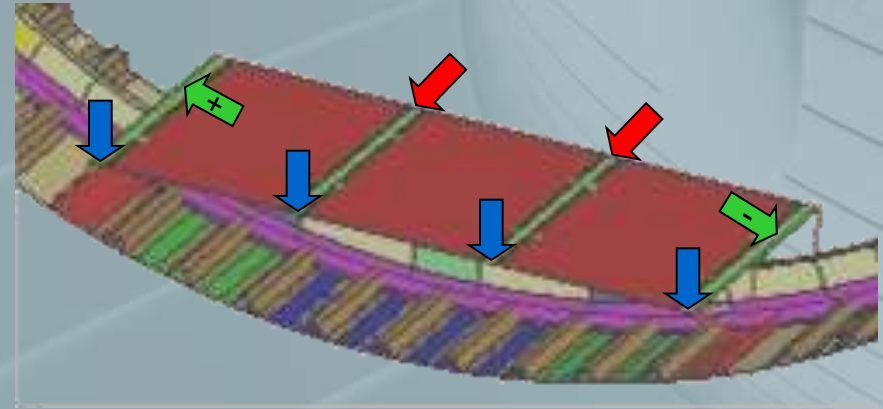

Approach:

- Stresses at stress recovery points (C-F) as FE output
- Stresses at G' and H' by linear stress assumption
- Calculation of local buckling RF by analytical theory (HSB)

Verification:

- Reference shell model of I-beam
- Calculation of buckling modes with linear buckling analysis

Result (critical load):

buckling mode	2D		1D rotation fix		1D rotation free	
	[N]	[%]	[N]	[%]	[N]	[%]
global	117790	100	119661	102	119661	102
local flange	116520	100	220800	189	72360	62
local web	282280	100	289800	103	166100	59

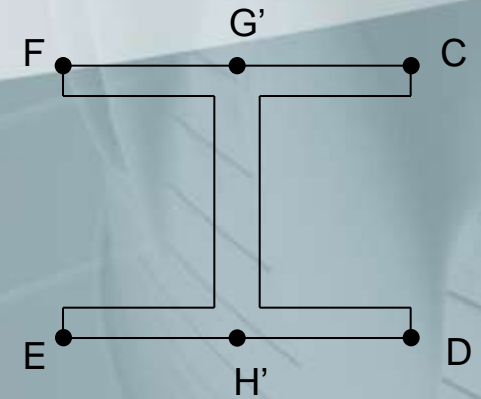
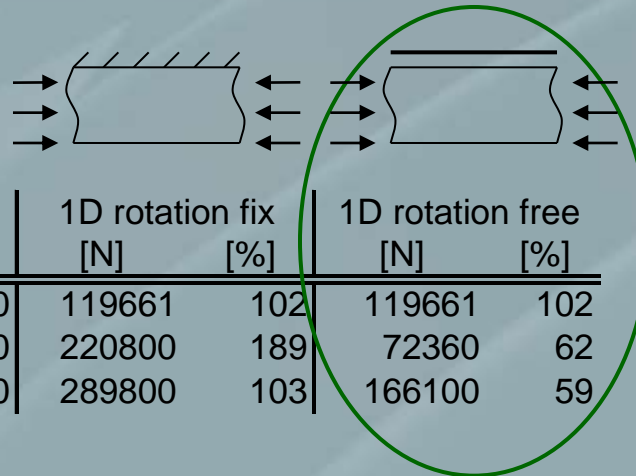

global buckling mode:



local buckling mode:

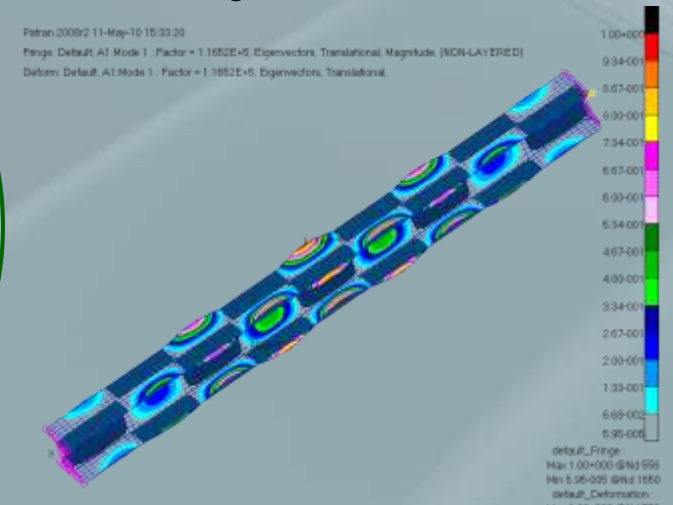

- Introduction cargo floor
 - Current design
 - Basic requirements
- Concept development approach
- **Cargo floor concepts**
 - C0 Reference concept
 - Overview of new concepts
 - C1 Cross-rib
 - C5 Corrugated sheet
- Summary

C0 Reference concept

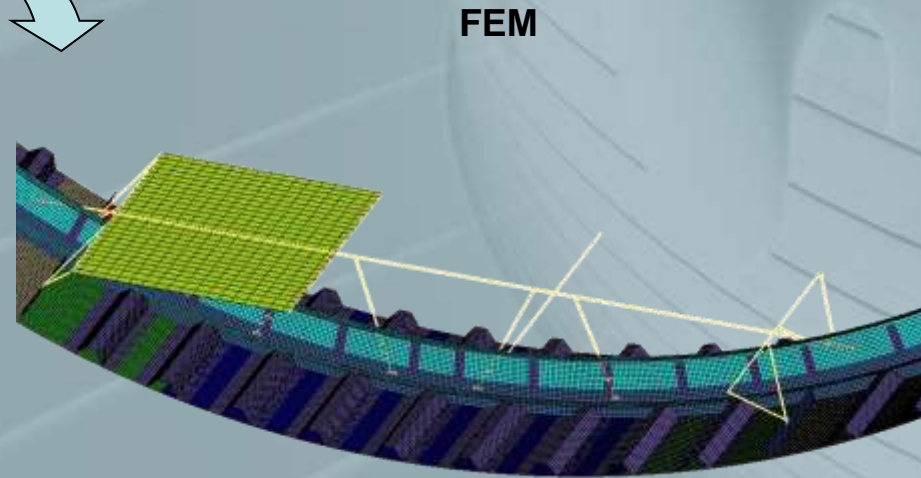
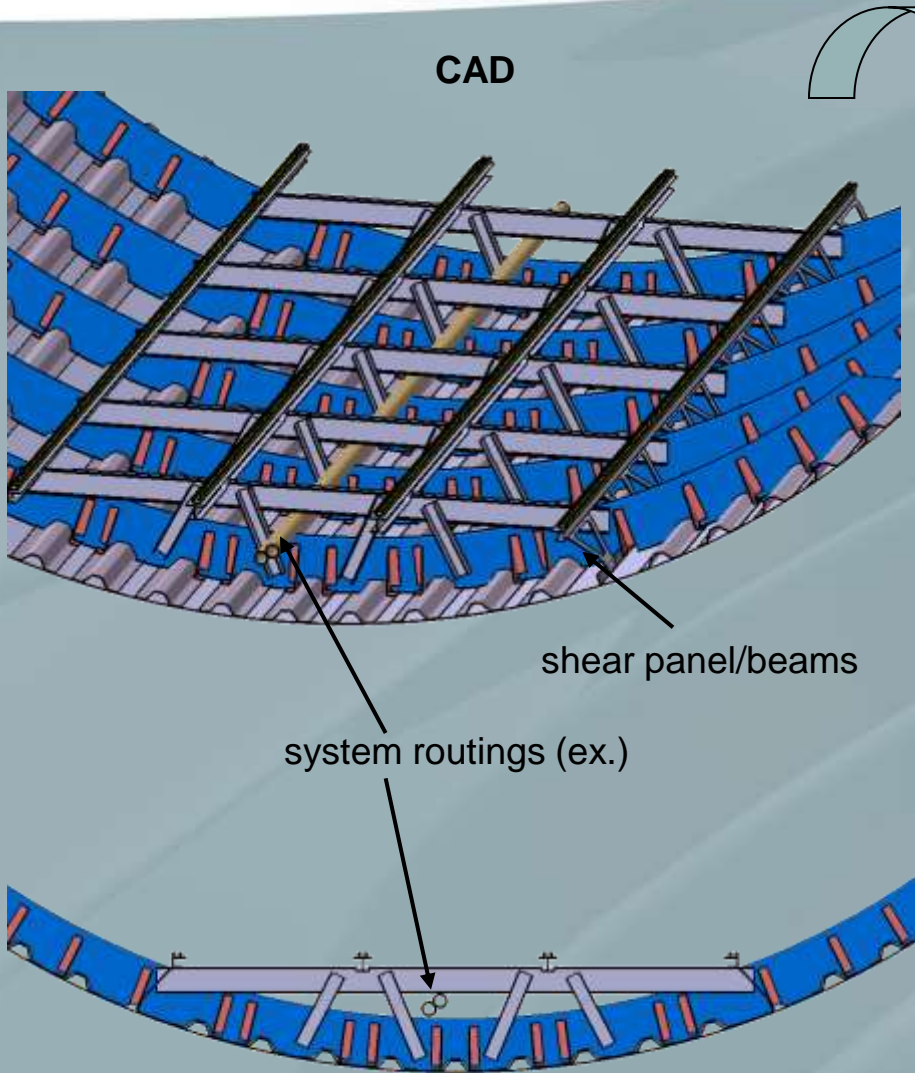

- Design directly derived from conventional (single aisle) cargo floor design
- Sizing with OptiStruct; same constraints as used for new concepts!!!



Reference concept for objective weight comparison

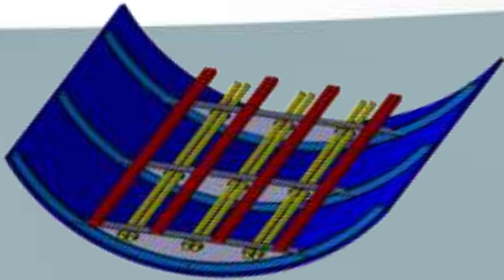

C1 Cross-rib concept:

- cross-beam, frame (below cargo floor) and web are used as one beam → cross-rib

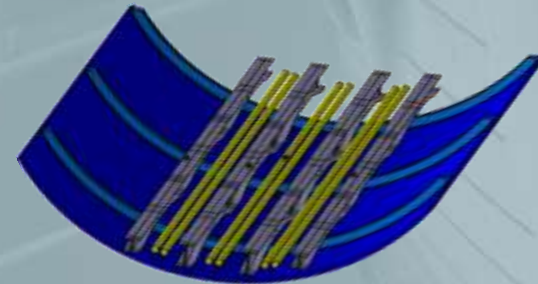

C2 Long-beam concept (baseline):

- load adapted and low-cost longitudinal beams

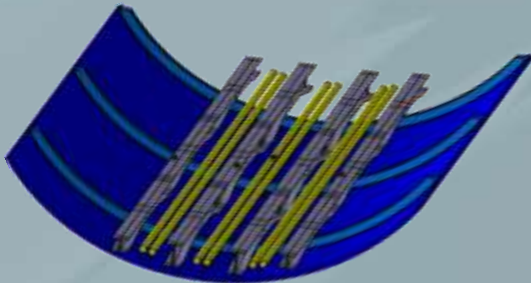

C2 Long-beam concept (advanced):

- direct transfer of the x-loads into the skin

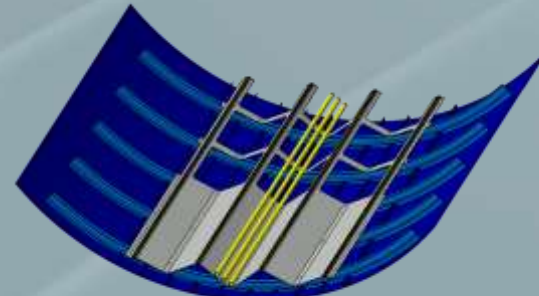

C5 Corrugated sheet concept:

- framework structure with low tooling effort

Cargo floor concepts – overview

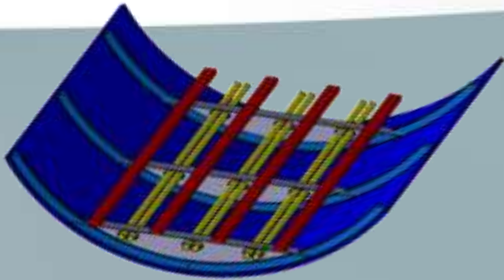

C1 Cross-rib concept:

- cross-beam, frame (below cargo floor) and web are used as one beam → cross-rib



C2 Long-beam concept (baseline):

- load adapted and low-cost longitudinal beams

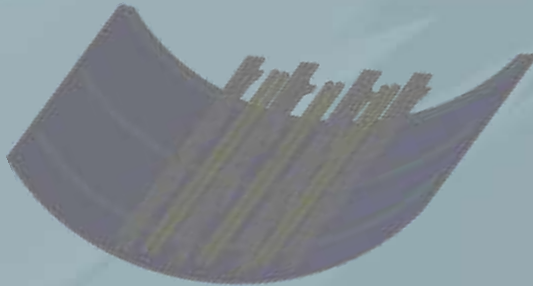

C2 Long-beam concept (advanced):

- direct transfer of the x-loads into the skin

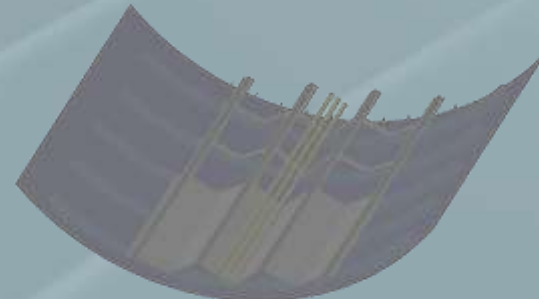

C5 Corrugated sheet concept:

- framework structure with low tooling effort

C1 Calculation of cross-rib web (cut-outs)

Issue: Positioning of cut-outs for systems

Solution:

- topology optimisation with different targets (residual mass [%])
- superposition of the results
- determination of the intersection for the system cut-outs

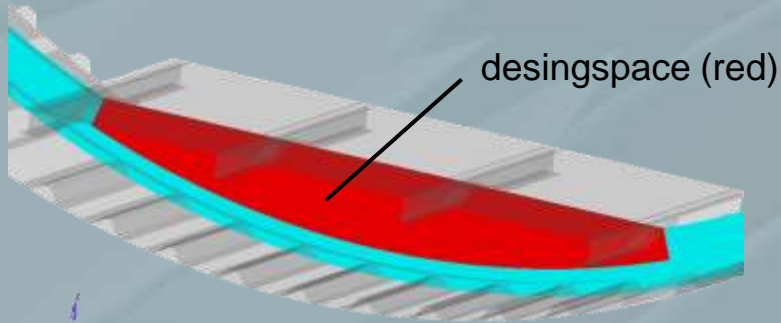

change of topology

residual masses:

30%

40%

50%

60%

70%

80%

90%

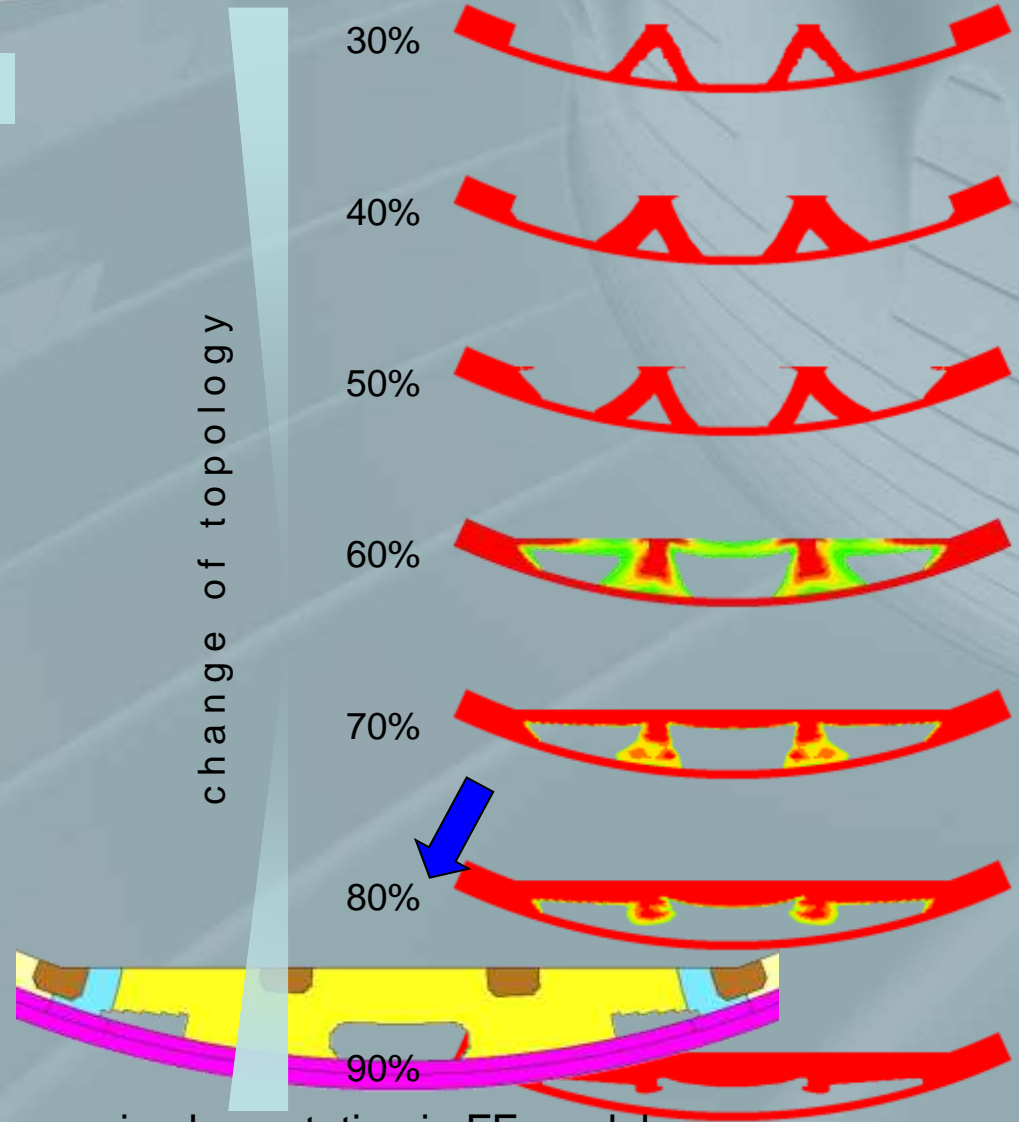

implementation in FE-model

C1 Design

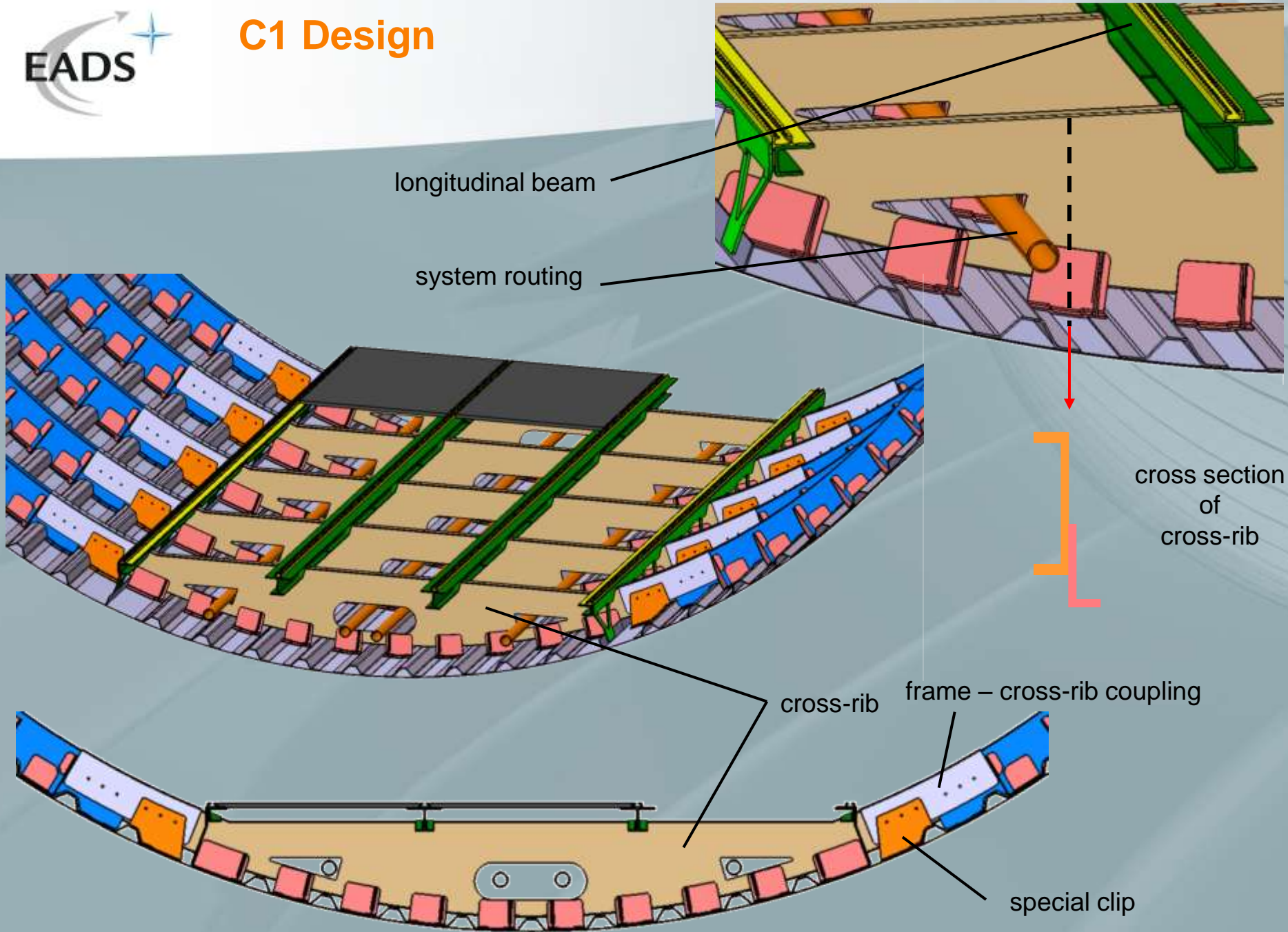

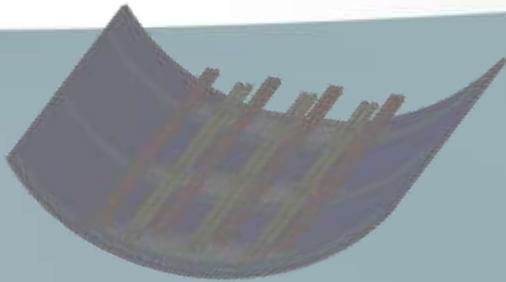

C1 Cross-rib concept:

- cross-beam, frame (below cargo floor) and web are used as one beam → cross-rib

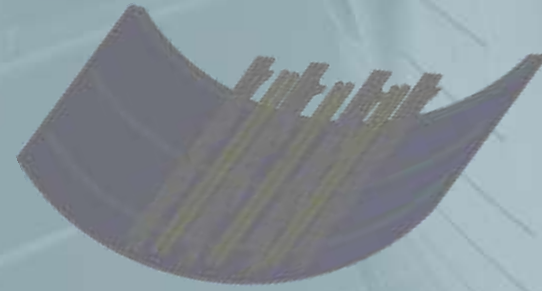

C2 Long-beam concept (baseline):

- load adapted and low-cost longitudinal beams

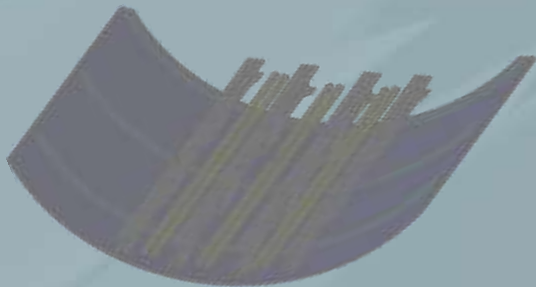

C2 Long-beam concept (advanced):

- direct transfer of the x-loads into the skin

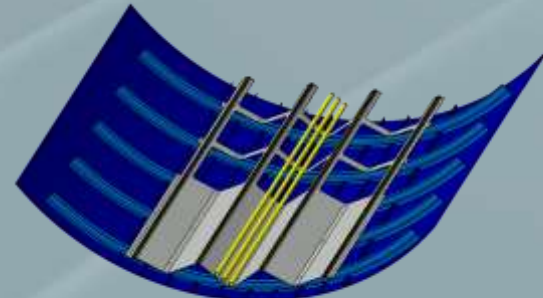

C5 Corrugated sheet concept:

- framework structure with low tooling effort

Structural idea

- simple VAP tooling
- framework structure for the main loads
- cut outs for weight saving and for accessibility

Potential

- low cost manufacturing
- quick & cheap assembly (longitudinal tolerances are uncritical)
- easy installation of longitudinal systems
- pre-assembled and pre-equipped modules

Major challenges

- connection to frame
- missing cross beam

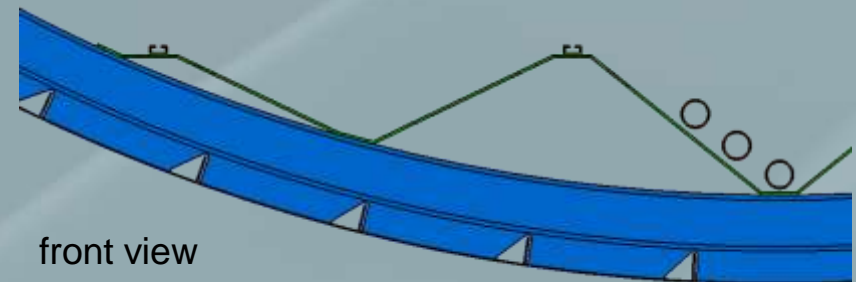
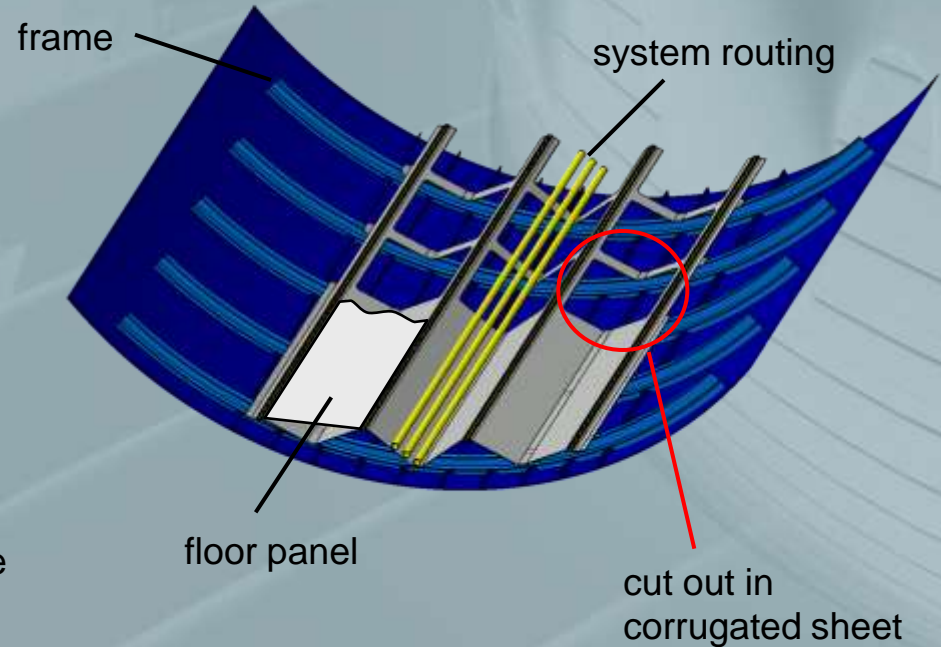

Options of topology

Variant A

- fully integral part
- low amount of joints

Variant B

- better stability
- load adapted adjustment of z-beams

Variant A

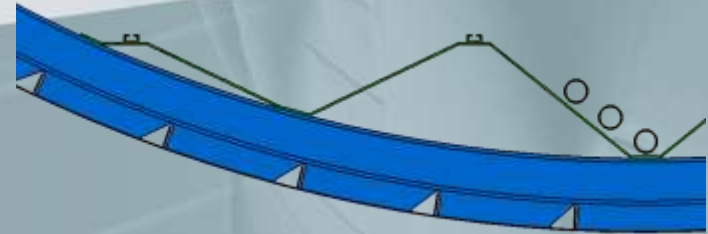

Variant B



Design of z-beams

- T-stringer – effective concerning stability

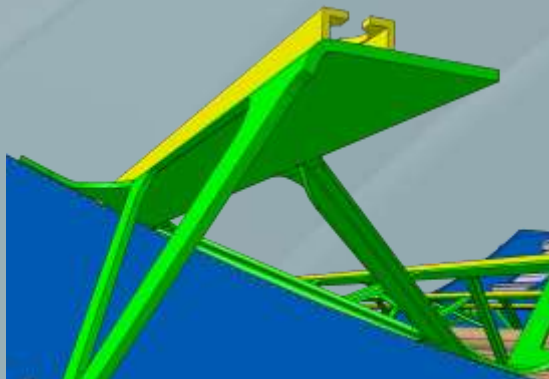

- curved – low manufacturing costs

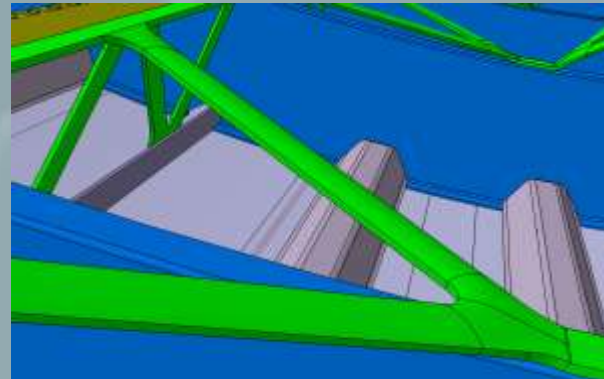

Target:

minimum of compliance

Constraints:

- different target volumes (parameter study)
- no strength
- no stability

Design space:

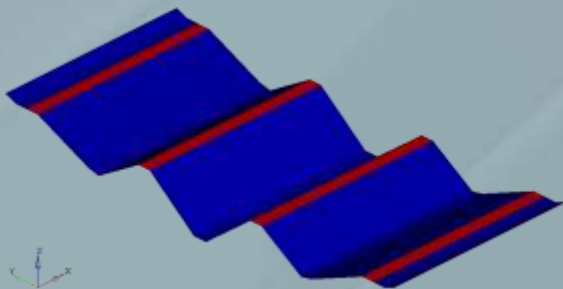

Result of Optimisation:

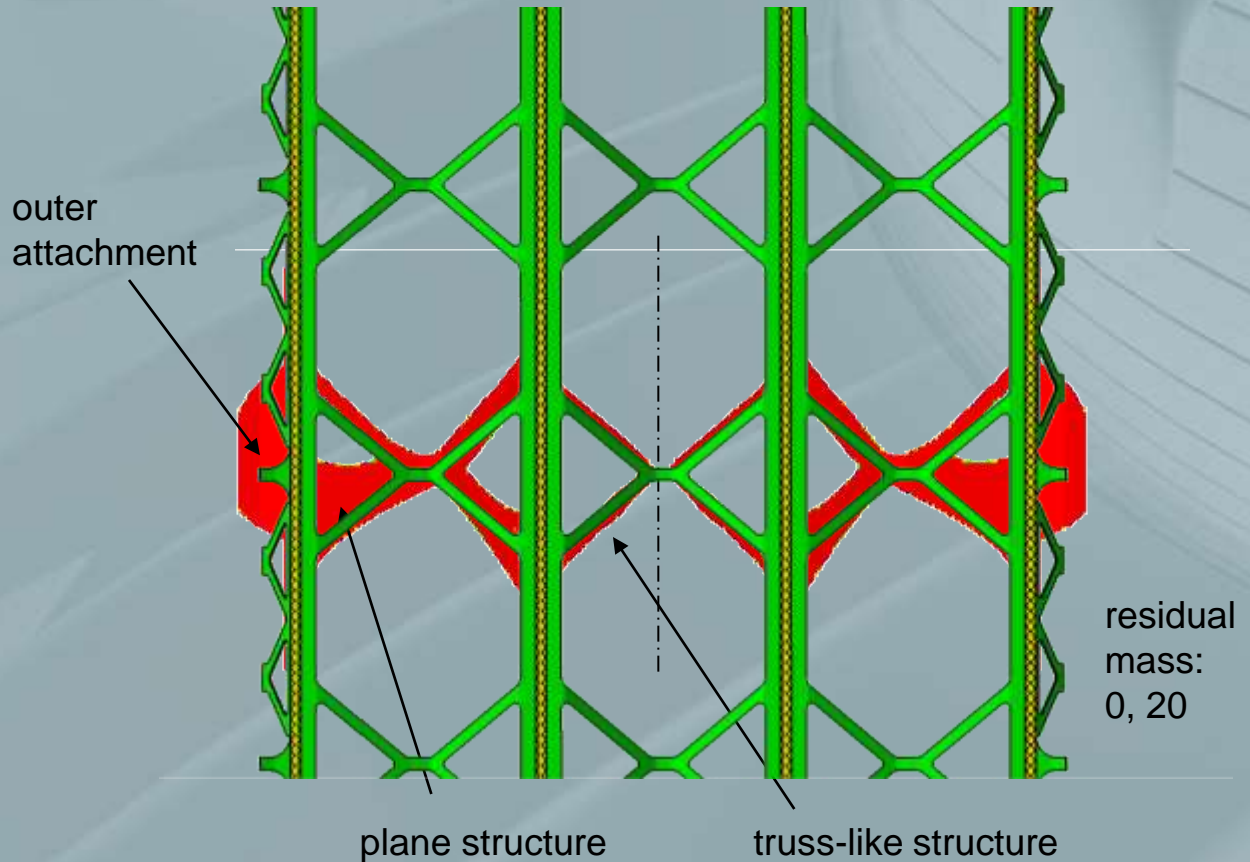

User influence:

- chosen target volume
- interpretation of results (transfer to design)

1. Step:

Design space

Target: minimum of compliance

Constraints: max. residual mass

Result:

load introduction

2. Step:

Design space

Result:

plane structure

truss-like structure

residual mass: 0,15

3. Step:

Sizing of both variants (A and B) → Difference of weight < 5% → Further elaboration of variant A

FE-model:

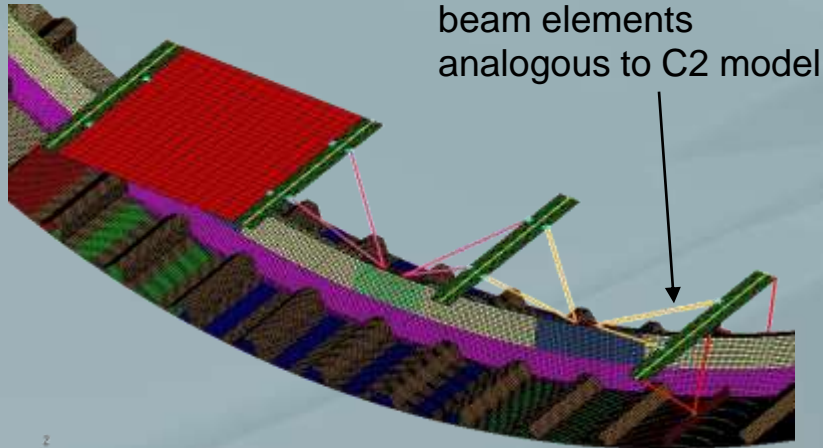

Properties in frame:

LT: quasiisotropic CFRP

Frame: web -> triax; flange -> triax + UD

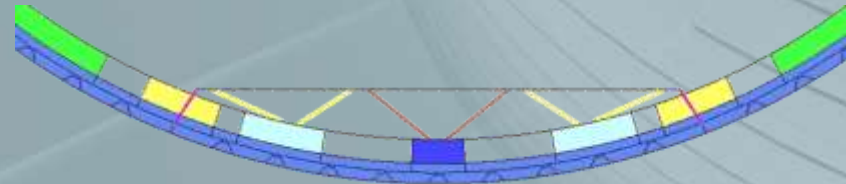

FE-result (strain):

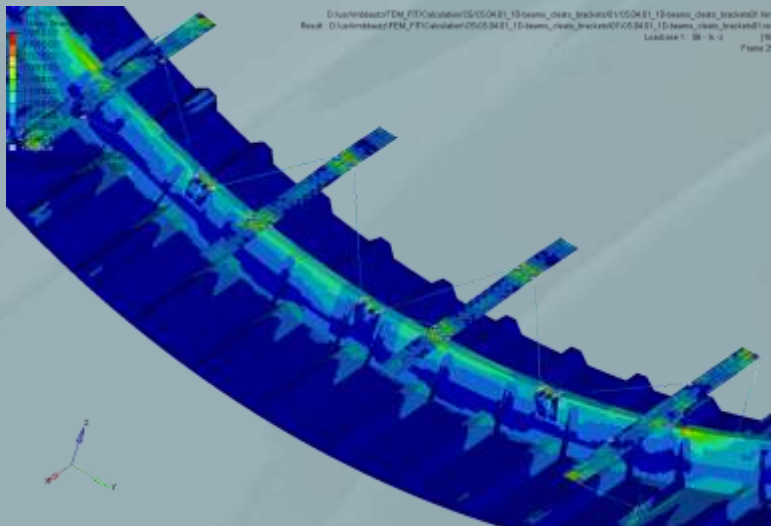

Resume:

- balanced distribution of strains
- only slight strain peaks in connection areas

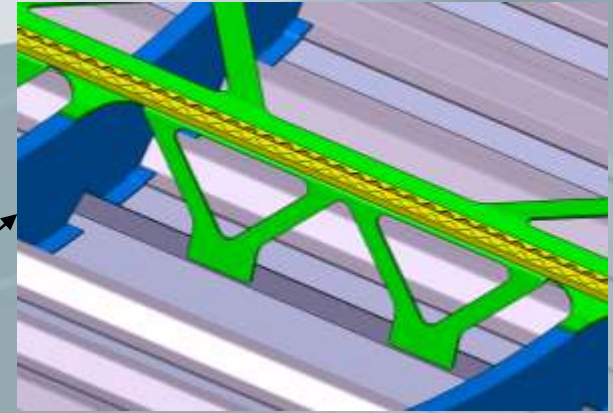
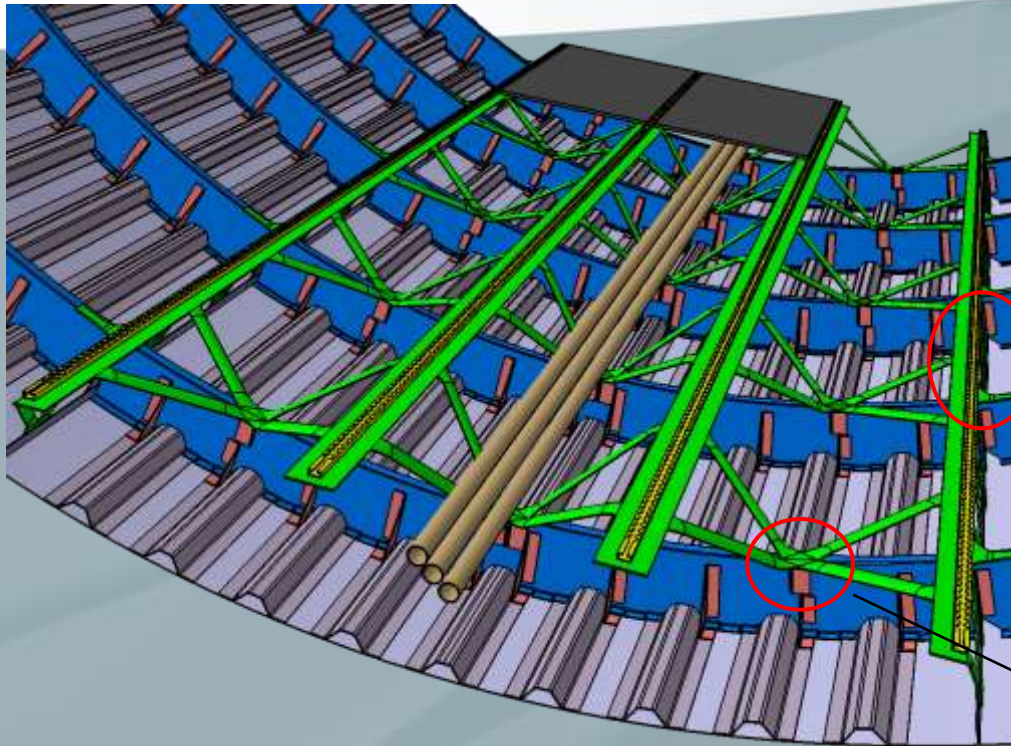

Linear alignment of trusses

- manufacturing with continuous CFRP material
- but, limited space for riveting

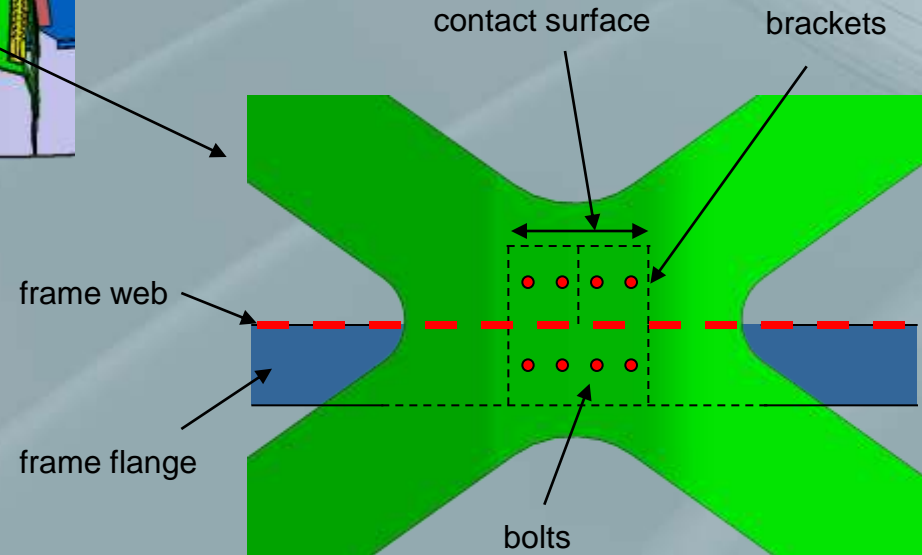

- Introduction cargo floor
 - Current design
 - Basic requirements
- Concept development approach
- Cargo floor concepts
 - C0 Reference concept
 - Overview of new concepts
 - C1 Cross-rib
 - C5 Corrugated sheet
- **Summary**

- Several cargo floor concepts are investigated with the help of diverse optimisation techniques
- Four final concepts (and one reference concept) are elaborated in detail, including
 - sizing
 - design
 - first assembly & system integration concepts
- Weight comparison results:

C0 reference

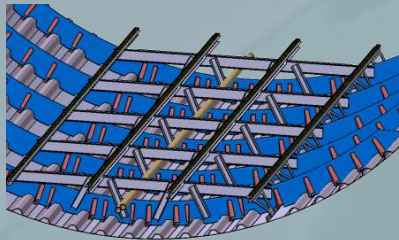

C1 cross-rib

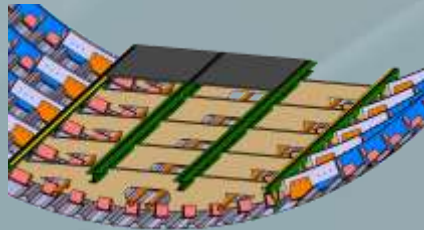

C2 longitudinal beam
baseline / advanced

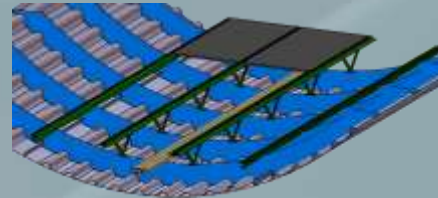

C5 corrugated sheet

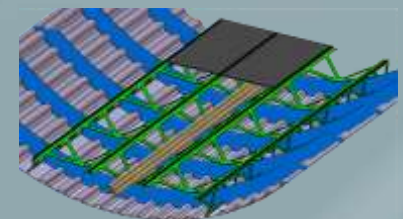

weights:

100 %

129 %

85 % / 90 %

97 %

Optimisation assisted concept development

What is fulfilled?

- Optimal results?
 - Local optima: yes – global optima: not with this approach!
 - But anyway, better result than developing “by hand”!
- New/unexpected concept?
 - Yes, but case dependent!
- Objective concept comparison (in terms of weight)?
 - Partially!
- Fast process?
 - Yes, especially for concept changes!



Thank you for your attention!

...

Any question?

