

MCE-5 VCRi Engine: Topological and Free Shape Optimization of the VCR Control Rack

Dr. Matthieu DUCHEMIN
R&D Engineer
Mechanical and Simulation Analysis

October 28th, 2010



1. Overview of MCE-5 DEVELOPMENT

- a. Corporate Information
- b. Objectives
- c. What is VCR?
- d. MCE-5 VCRi technology
- e. Current development status

2. MCE-5 VCR-i technology optimization program

- a. Typical optimization workflow
- b. Results of the workflow on some of the VCR parts

3. Optimization of the control rack

- a. Actual definition
- b. Topology optimization
- c. Free shape optimization
- d. Validation

Conclusion



1. Overview of MCE-5 DEVELOPMENT

- a. Corporate Information
- b. Objectives
- c. What is VCR?
- d. MCE-5 VCRi technology
- e. Current development status

2. MCE-5 VCR-i technology optimization program

- a. Typical optimization workflow
- b. Results of the workflow on some of the VCR parts

3. Optimization of the control rack

- a. Actual definition
- b. Topology optimization
- c. Free shape optimization
- d. Validation

Conclusion



Overview of MCE-5 DEVELOPMENT

Corporate information

More details : www.vcr-i.com



Creation date: January 2000

Head office: Lyon – FRANCE

Structure: Joint stock company with a capital of 1,278,174.80 €

Funds invested in R&D to 31 August 2010: 55 M€

Financing: Private investors (65%), public financing (27%), industrial partners (8%).

Number of private shareholders: 333

Patent portfolio: 18 families, more than 300 patents in 14 countries

Headcount: 38

Number of partner companies: > 60

Technical and Financial partners involved in the R&D programs: CERTAM, Danielson Engineering, Safe automotive, 12 tier-one automotive industry suppliers (confidential).

Institutional partners:



Labels:



Overview of MCE-5 DEVELOPMENT

Objectives

More details on www.vcr-i.com

- To develop innovative solutions in the field of automobile and energy: prototyping, functional validation, mass-production processes identification and development, economical and industrial validation
- To enter IP agreements with carmakers and to collaborate with them for final validation of the solutions, ready for mass production
- To enter into long term cooperation with carmakers and the automotive industry
 - *Current focus: Variable Compression Ratio (VCR)*



Overview of MCE-5 DEVELOPMENT

What is VCR?

Compression Ratio: $(V1+V2)/V1$

Variable Compression Ratio principle: make V1 variable

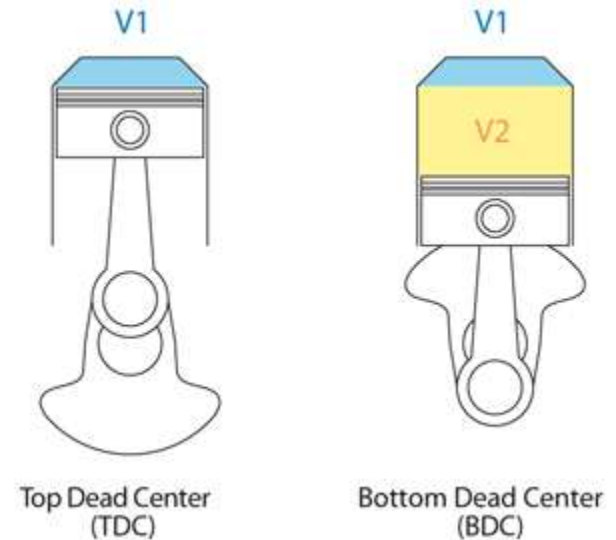

- **Energetic & Economic Benefits**
 - 6 to 33 % reduction (avg 20 %) in CO2 emissions of produced vehicles as of 2016-2017 compared with 2009/2010 production
 - Production cost reduction when compared with identical CO2/performance ratio & emission standards
- **Strategic & Commercial Benefits**
 - Better compliance of production with CO2 emission reduction targets (EU, USA...)
 - Reduction in cost/km for end customers
 - Increase in vehicle attractiveness

Overview of MCE-5 DEVELOPMENT

MCE-5 VCRI technology

Main advantages:

- Wide control range: 6 →15
- No change in piston motion
- Low friction
- Cylinder by cylinder control
- Minimal energy consumption

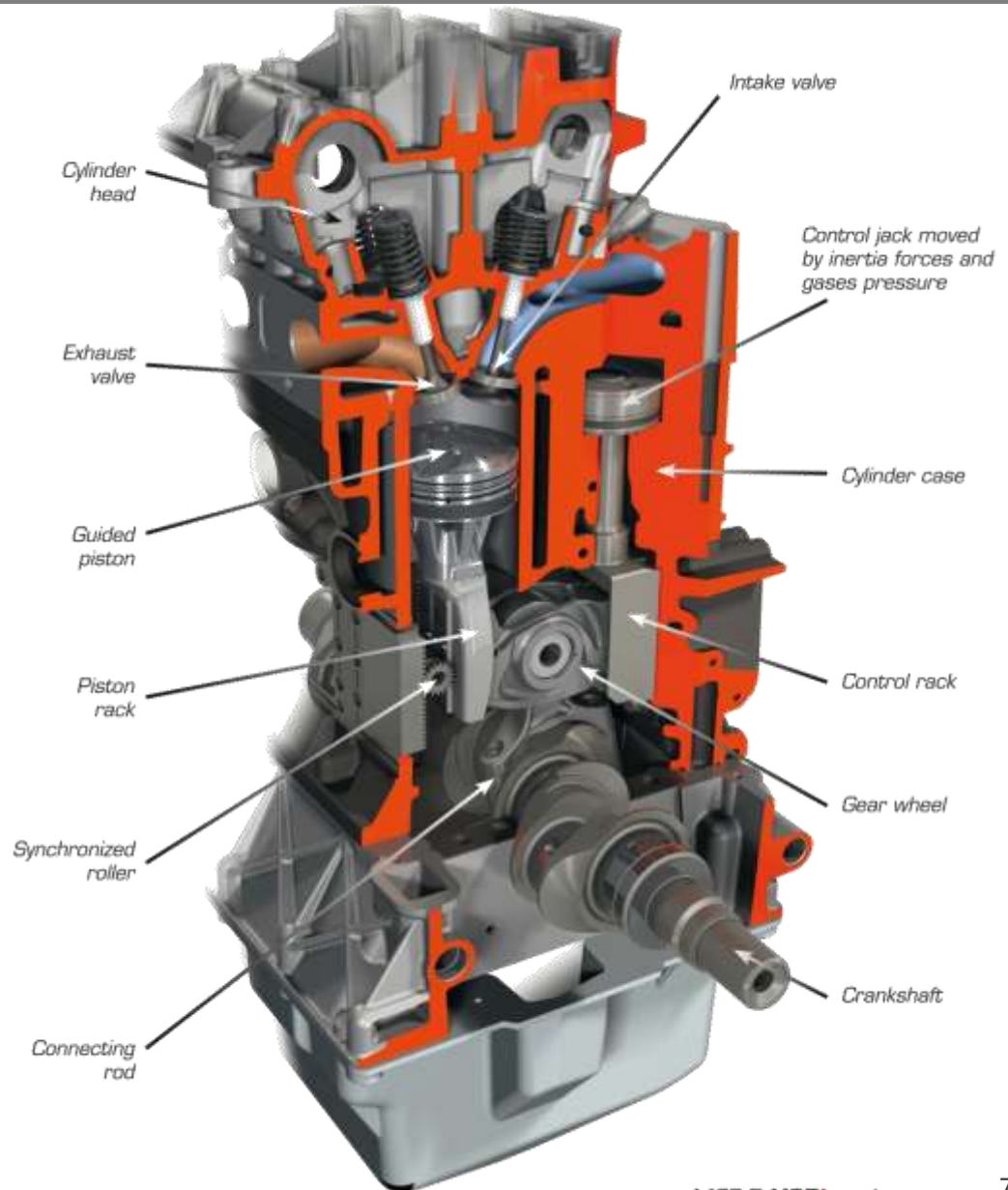

Overview of MCE-5 DEVELOPMENT

Current development status

- **Innovative components:**
 - Product and process validated
 - Durability test ongoing
 - **Weight optimization ongoing**
- **Energetic performance and component validation**
 - 6 single cylinder engines (5 PFI and 1 GDI)
 - 7 multi-cylinder engines
 - 4 MPFI: 1.5 L, 160 kW, 420 Nm
 - 3 GDI: 1.5 L, 180 kW, 480 Nm
 - Running on 5 test benches
- **Development and demonstration vehicle**
 - General performance and reliability
 - Driving dynamics
 - Basic NVH assessments



1. Overview of MCE-5 DEVELOPMENT

- a. Corporate Information
- b. Objectives
- c. What is VCR?
- d. MCE-5 VCRi technology
- e. Current development status

2. MCE-5 VCR-i technology optimization program

- a. Typical optimization workflow
- b. Results of the workflow on some of the VCR parts

3. Optimization of the control rack

- a. Actual definition
- b. Topology optimization
- c. Free shape optimization
- d. Validation

Conclusion



MCE-5 VCR-i technology optimization program

Typical optimization workflow

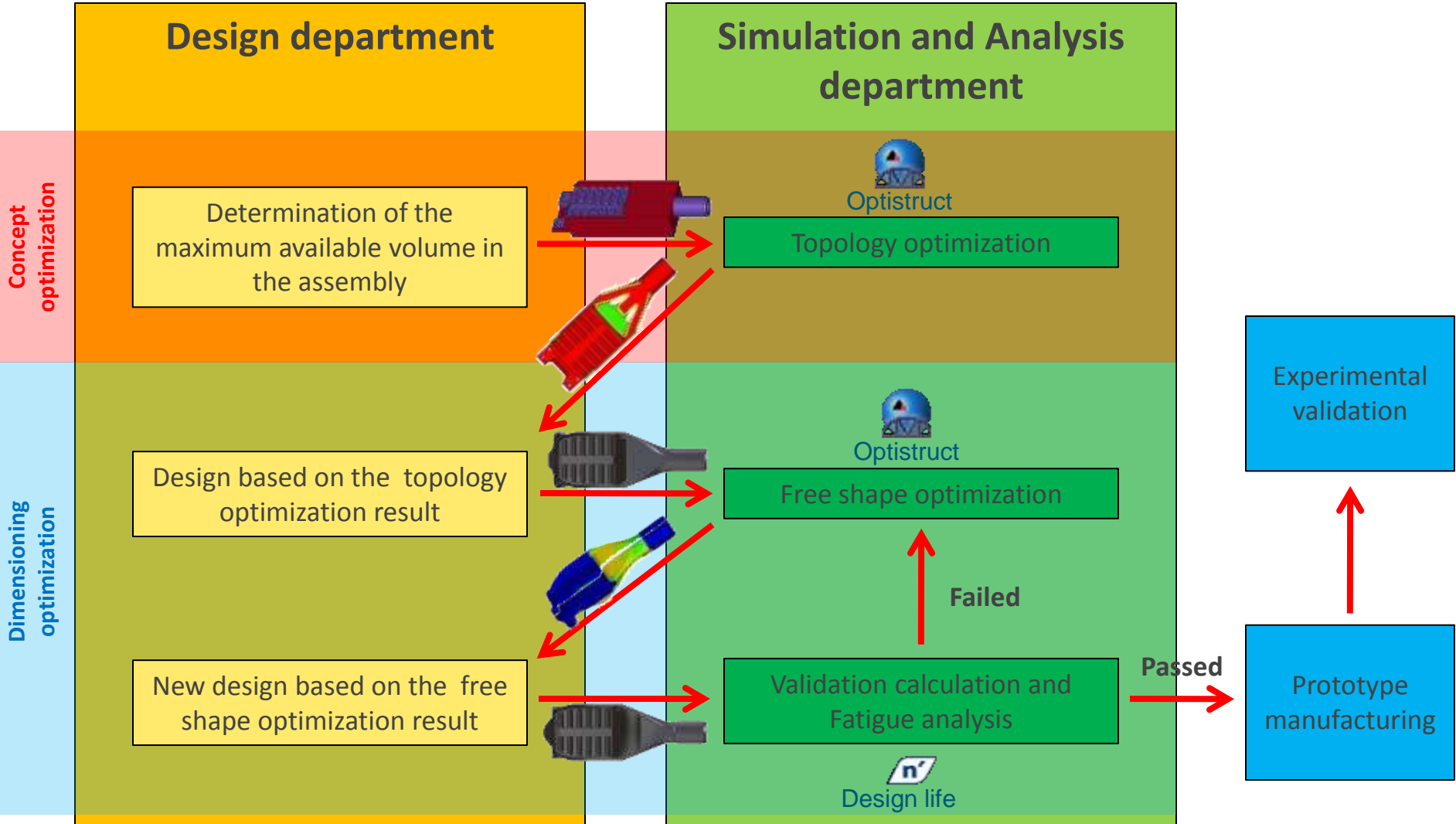

MCE-5 VCR-i technology optimization program

Results on some of the MCE-5 innovative parts

Piston rack



Weight reduction : 17%
Load capacity unchanged



Piston



Weight reduction : 0%
Load capacity increased by 30%



Gear wheel



Weight reduction : 0%
Load capacity increased by 20%



Control rack



1. Overview of MCE-5 DEVELOPMENT

- a. Corporate Information
- b. Objectives
- c. What is VCR?
- d. MCE-5 VCRi technology
- e. Current development status

2. MCE-5 VCR-i technology optimization program

- a. Typical optimization workflow
- b. Results of the workflow on some of the VCR parts

3. Optimization of the control rack

- a. Actual definition
- b. Topology optimization
- c. Free shape optimization
- d. Validation

Conclusion



Optimization of the control rack

Actual definition

- Control rack reference 0110_A
 - Not a moving part → not yet optimized in mass: 1350 g
 - Only functional → rough design
- Cartography of the loads on the control rack teeth

Engine speed (rpm)	A/A'		B/B'		C/C'		D/D'		E/E'		F/F'	
	Min load (N)	Max load (N)	Min load (N)	Max load (N)	Min load (N)	Max load (N)	Min load (N)	Max load (N)	Min load (N)	Max load (N)	Min load (N)	Max load (N)
1000	0	2255	0	2995	0	4537	-2	10001	-163	21985	0	0
1500	0	10927	0	14601	0	21484	0	39864	-399	50780	0	0
2000	0	11559	0	14884	0	20801	0	35800	-1290	54647	0	0
3000	0	11989	0	14820	0	19084	-851	31553	-3735	44215	0	0
4000	0	8751	0	16384	0	18791	-1908	27023	-6927	41542	-2463	5056
5000	0	6762	0	15980	0	15599	-3514	17862	-11747	29955	-7062	4670
5500	0	2866	0	17285	0	16374	-3289	15060	-13181	26334	-13892	6628
6500	0	0	0	15787	0	13242	-1745	5545	-14167	0	-25294	0

Fatigue validation cycle 1

Fatigue validation cycle 2

Static validation loadcase



- Static validation loadcase: 2000 rpm – 128 bars of cylinder pressure – 39° crankshaft angle
- Fatigue validation cycle 1: 2000 rpm – 128 bars of cylinder pressure
- Fatigue validation cycle 2: 6500 rpm – inertia only

Optimization of the control rack

Actual definition 2000 rpm – 128 bars of cylinder pressure

Explicit calculation:

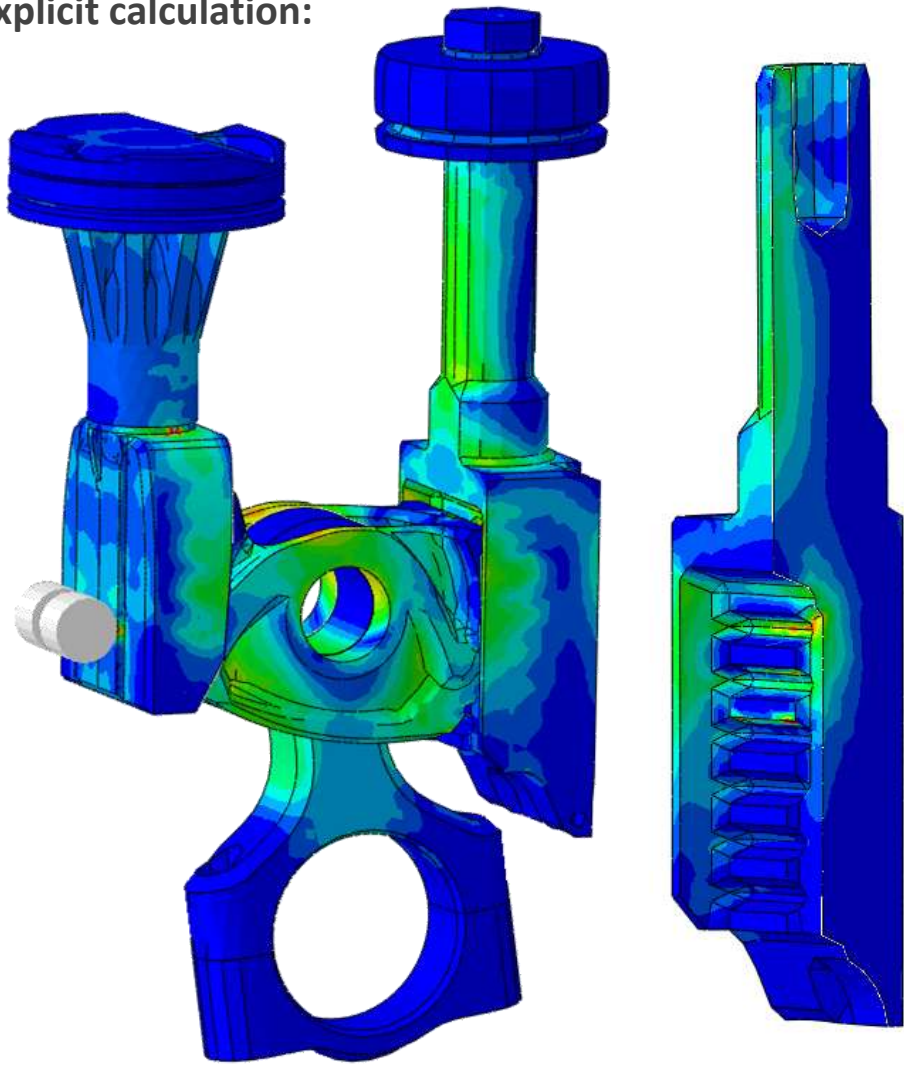

Implicit calculation:

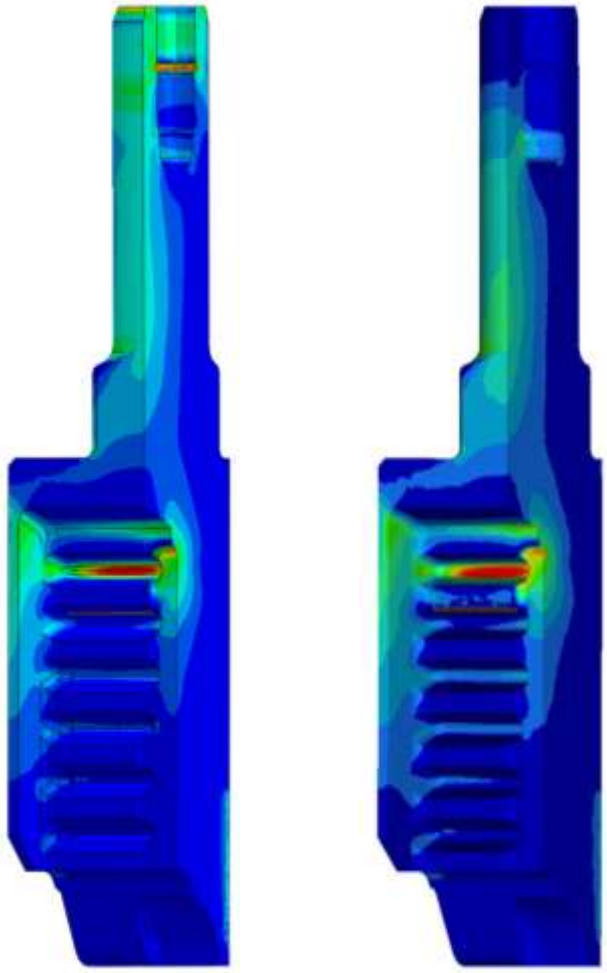

Complete model

Simplified model

Optimization of the control rack

Actual definition

2nd order mesh

Validation loadcase: 2000 rpm – 128 bars

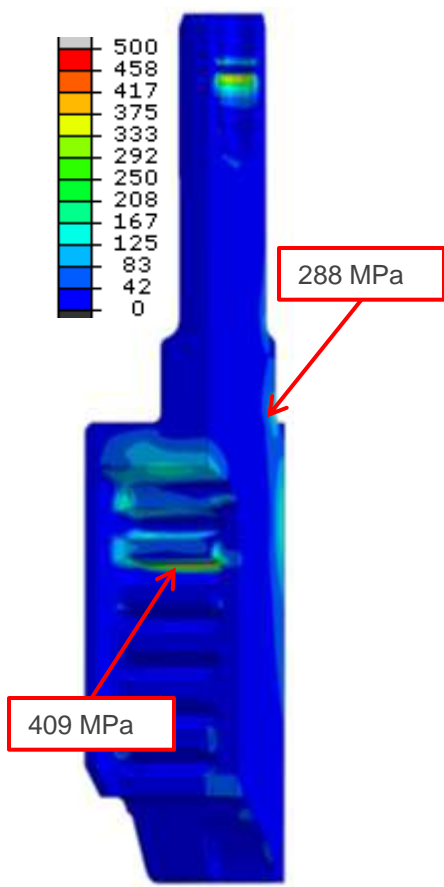

Max principal stress
(Scale: 0 → 500 Mpa)

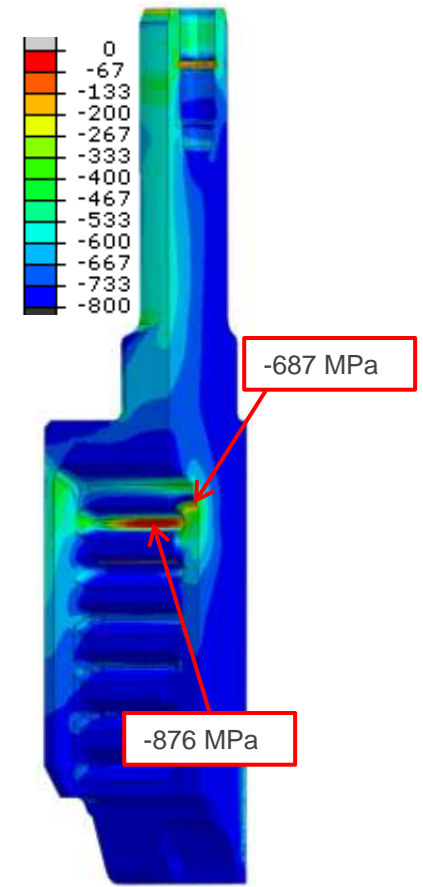

Min principal stress
(Scale: -800 → 0 Mpa)

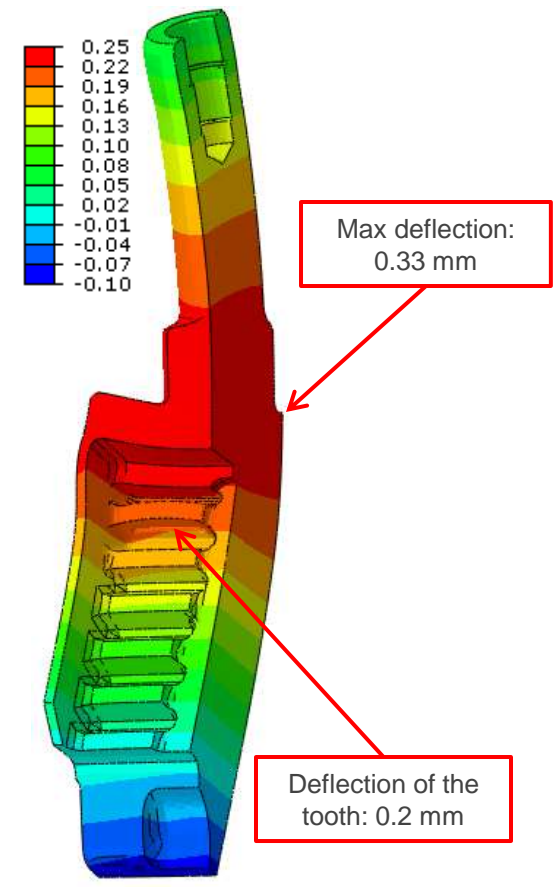

Horizontal deflection x100
(Scale: -0.1 → 0.25 mm)

Optimization of the control rack

Actual definition



**Fatigue validation cycle 1:
2000 rpm – 128 bars**

**Fatigue validation cycle 2:
6500 rpm – inertias only**

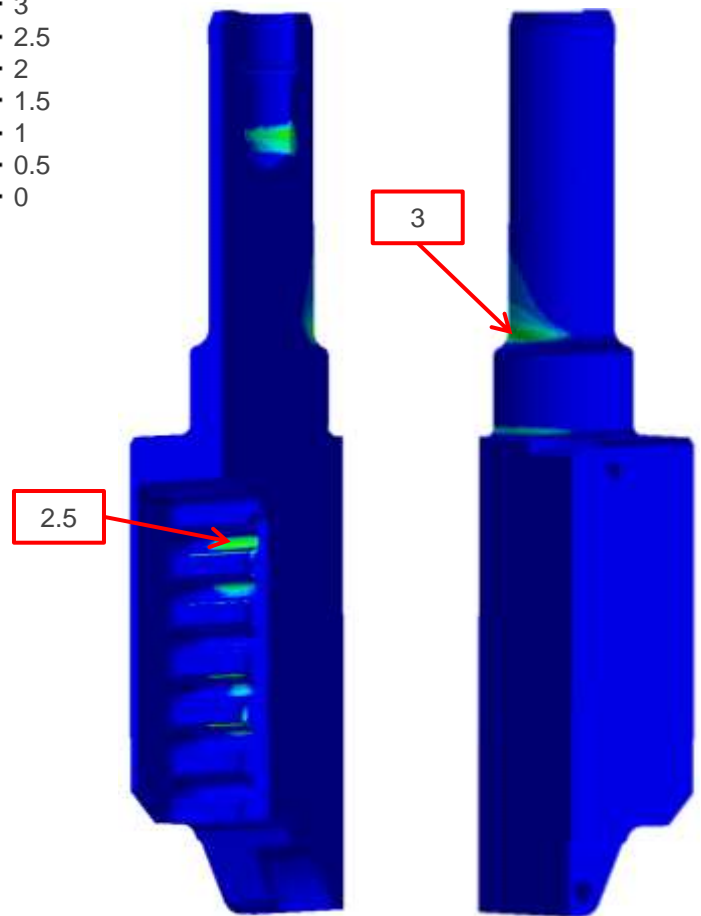
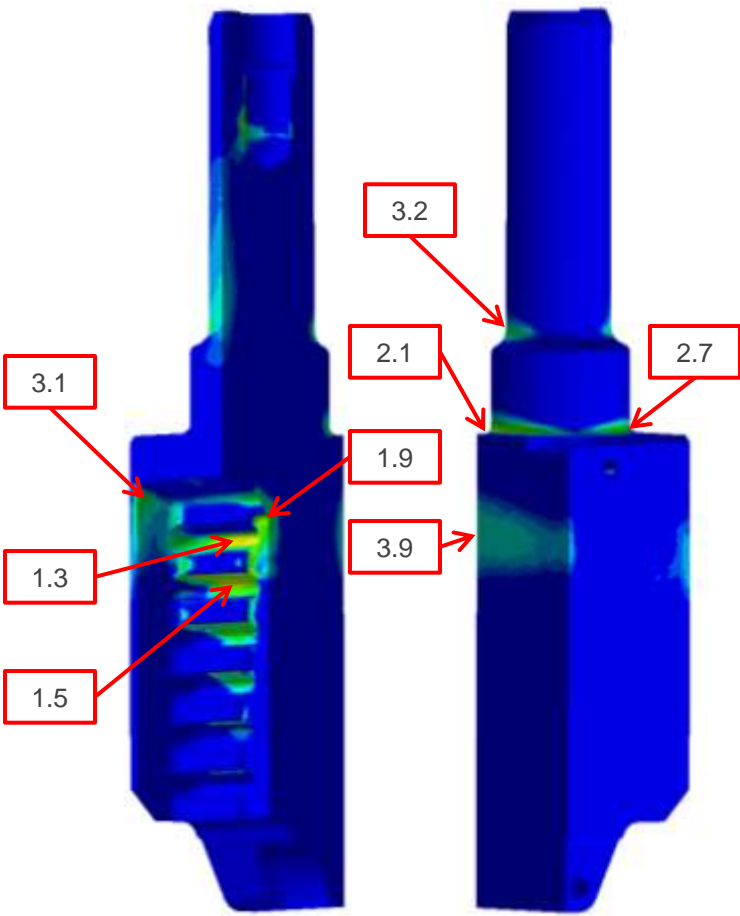
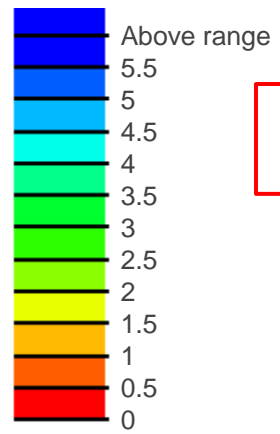

Optimization of the control rack

Topology optimization

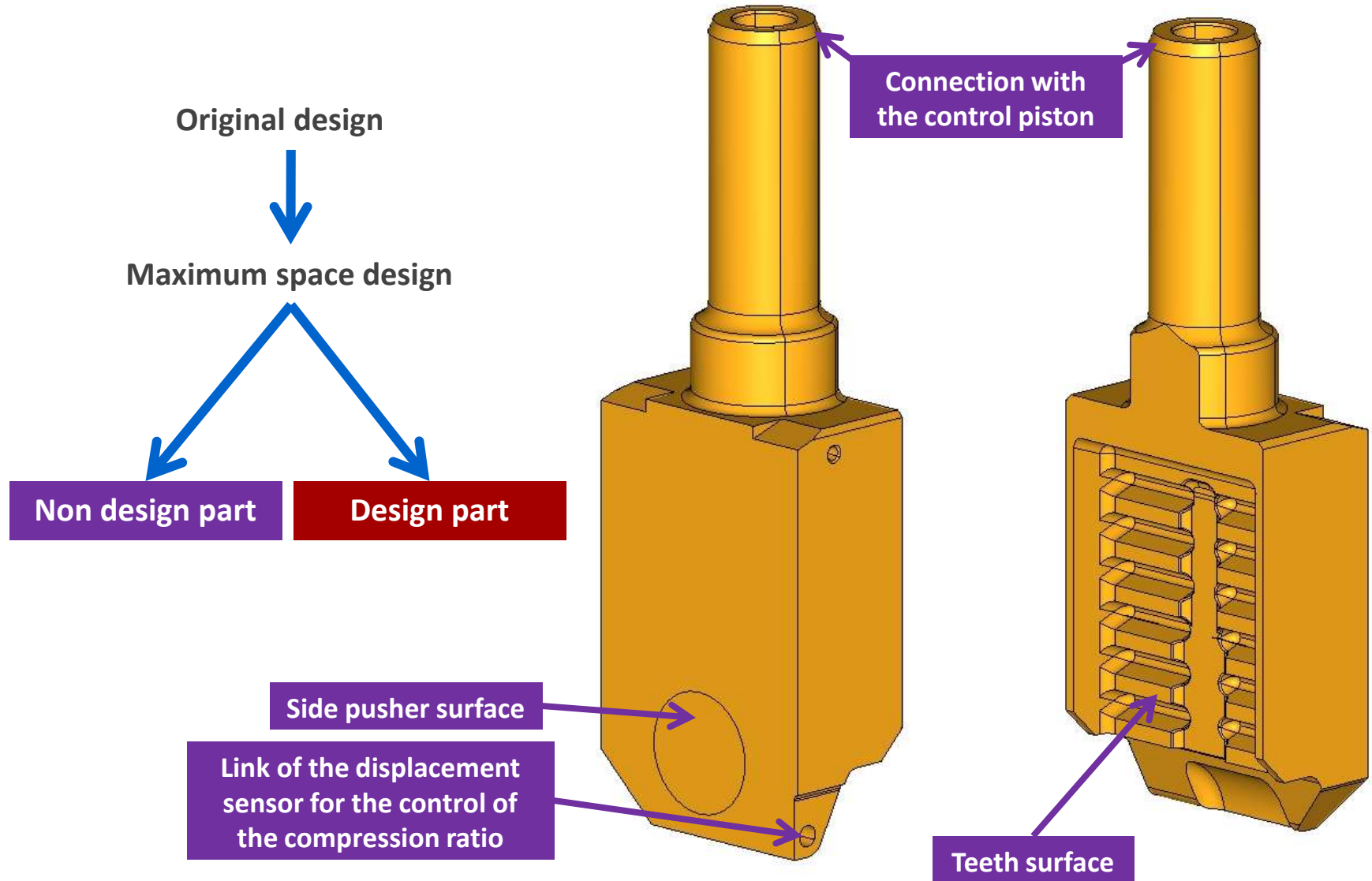

Optimization of the control rack

Topology optimization

- **Simplified calculation to increase speed:**
 - No contacts (forces applied directly on the teeth)
 - 1st order mesh
 - Regular mesh inside the design part
 - Links to other parts modeled with 1d rigid mesh
- **Variable of optimization:**
 - Density of the elements of the design part
- **Optimization objective:**
 - Minimum compliance for all loadcases (compliance index):

Engine speed (rpm)	A/A'		B/B'		C/C'		D/D'		E/E'		F/F'	
	Min load (N)	Max load (N)	Min load (N)	Max load (N)	Min load (N)	Max load (N)	Min load (N)	Max load (N)	Min load (N)	Max load (N)	Min load (N)	Max load (N)
1000	0	2255	0	2995	0	4537	-2	10001	-163	21985	0	0
1500	0	10927	0	14601	0	21484	0	39864	-399	50780	0	0
2000	0	11559	0	14884	0	20801	0	35800	-1290	54647	0	0
3000	0	11989	0	14820	0	19084	-851	31553	-3735	44215	0	0
4000	0	8751	0	16384	0	18791	-1908	27023	-6927	41542	-2463	5056
5000	0	6762	0	15980	0	15599	-3514	17862	-11747	29955	-7062	4670
5500	0	2866	0	17285	0	16374	-3289	15060	-13181	26334	-13892	6628
6500	0	0	0	15787	0	13242	-1745	5545	-14167	0	-25294	0

- **Optimization constraint:**
 - Mass under 950 g
- **Process constraint:**
 - Direction of draw (forge)

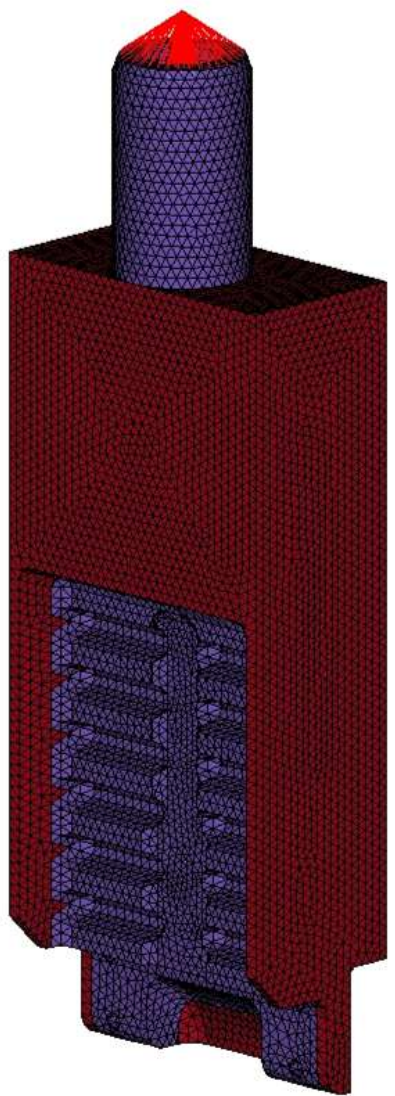

Optimization of the control rack

Topology optimization



Results:

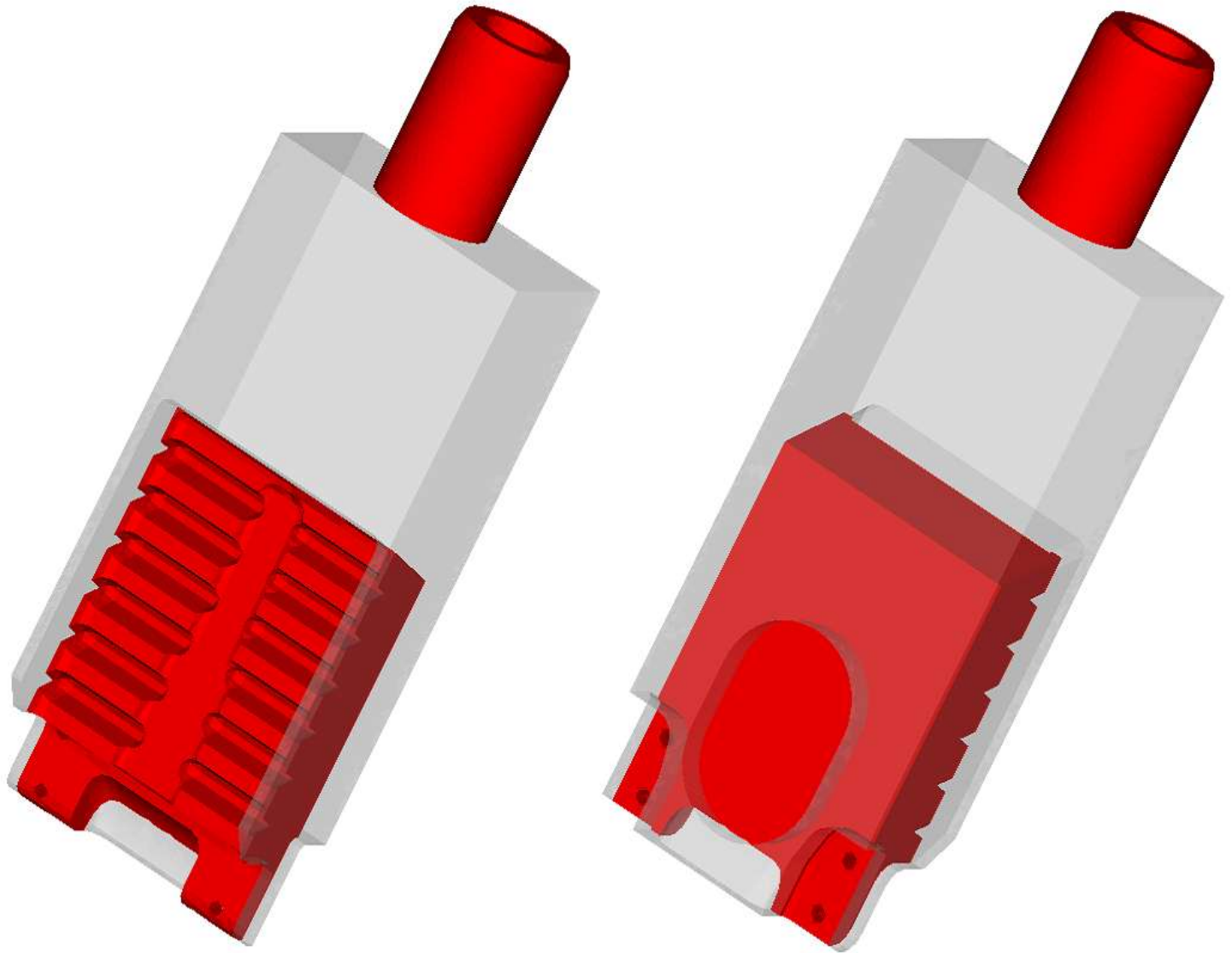

Optimization of the control rack

Free shape optimization

Topology result

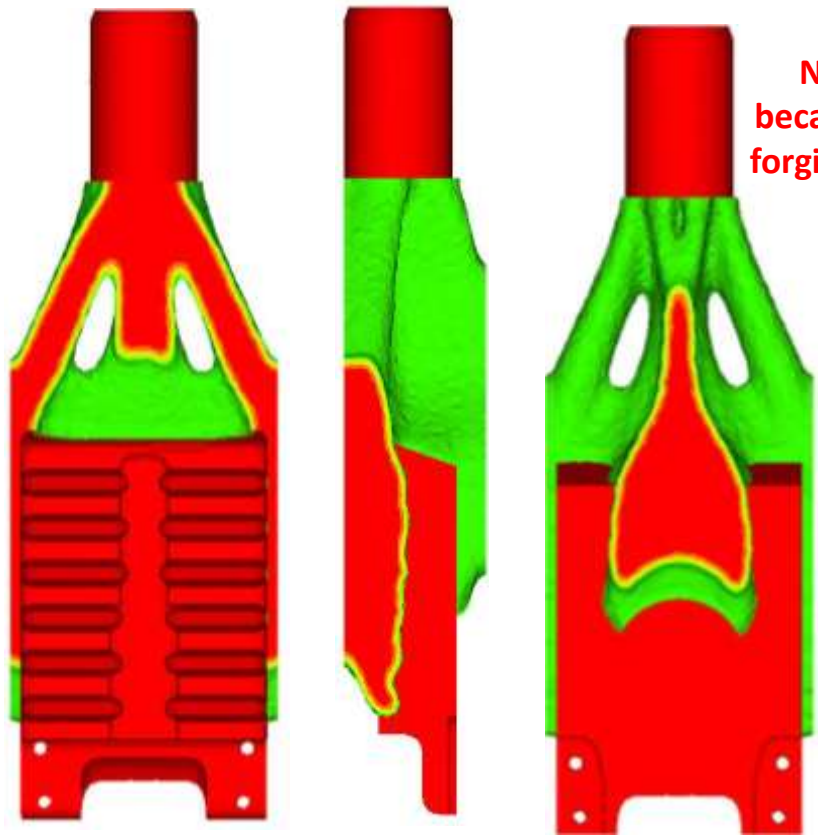

First proposal from the design department
(932 g)

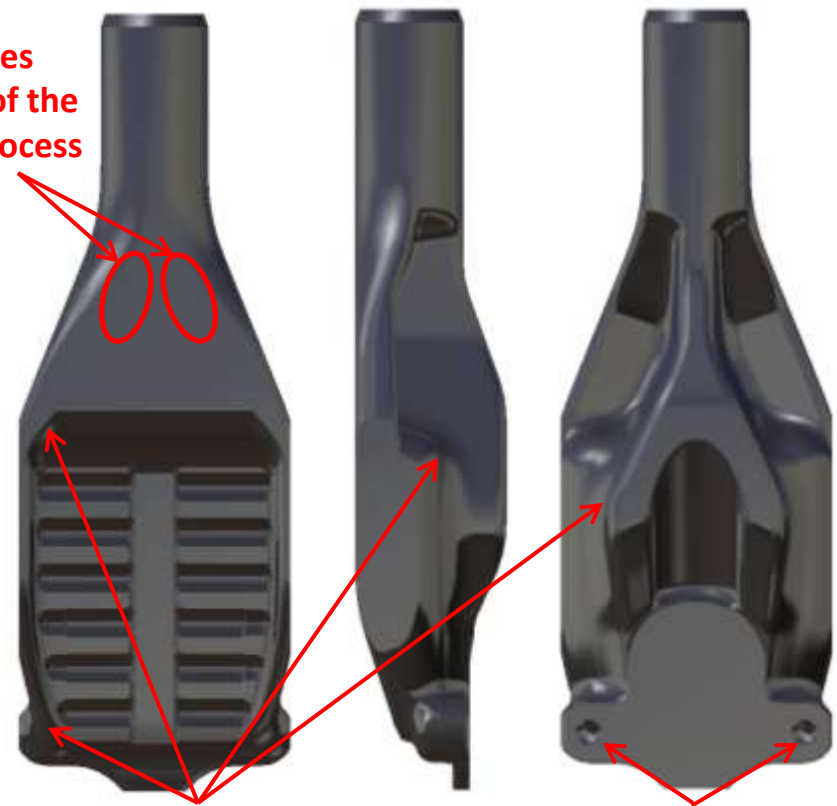

Smoothing the edges for easier forging

Only 2 bores for the link of the displacement sensor

Main differences

Optimization of the control rack

Free shape optimization

- **Simplified calculation to increase speed:**
 - No contacts (forces applied directly on the teeth)
 - 1st order mesh
 - Finer mesh using surface deviation
 - Links to other parts modeled with 1d rigid mesh
- **Variable of optimization:**
 - Position of the black nodes
- **Optimization objective:**
 - Minimum mass
- **Optimization constraint:**
 - Maximum stress under 500 MPa
 - Minimum stress over -1000 Mpa
 - Teeth displacement under 0.2 mm
- **Process constraint:**
 - Direction of draw (forge)



Optimization of the control rack

Free shape optimization



Results:

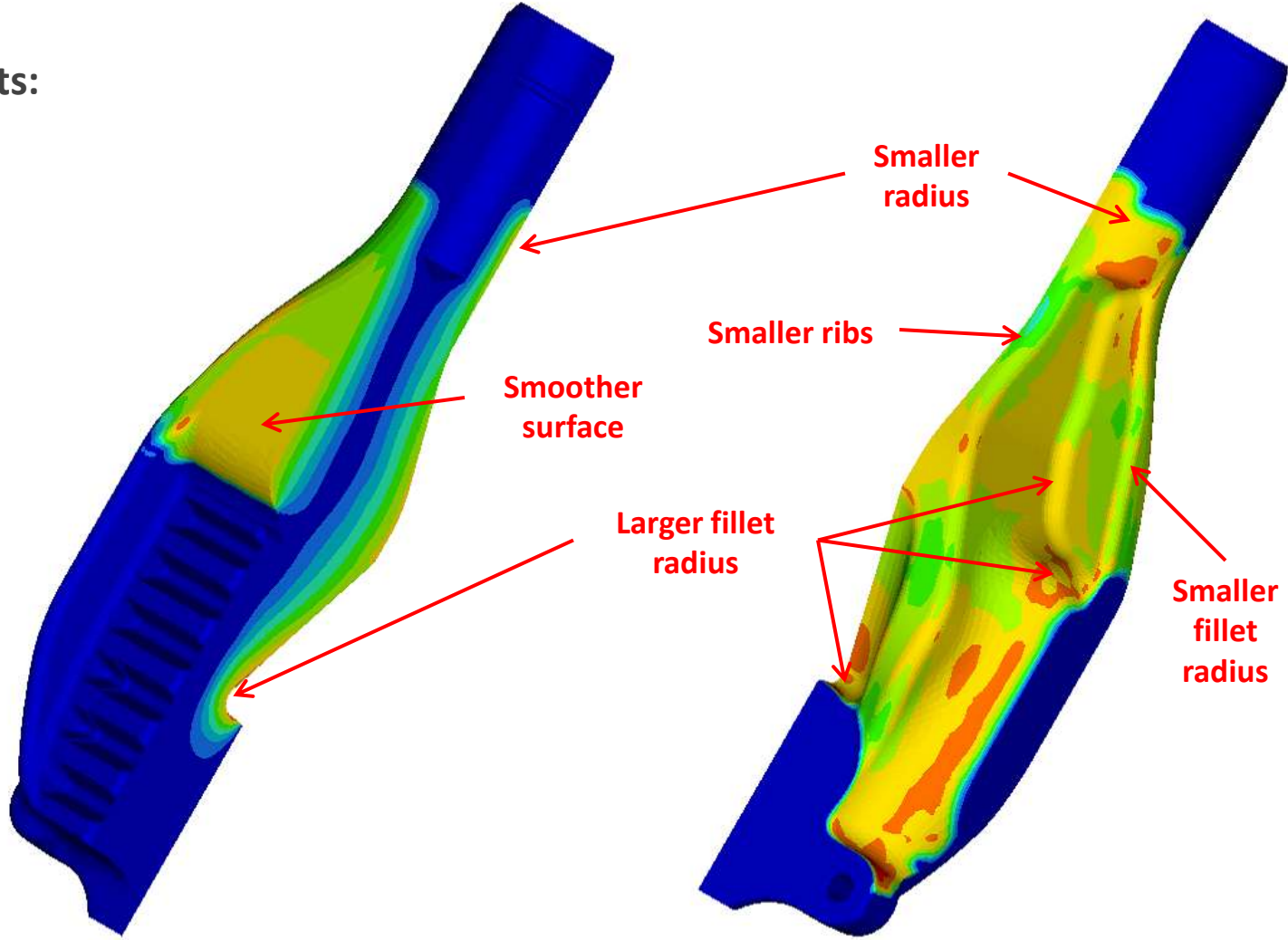

Optimization of the control rack

Free shape optimization

First proposal from the design department
(932 g)



Second proposal from the design department
(884 g)

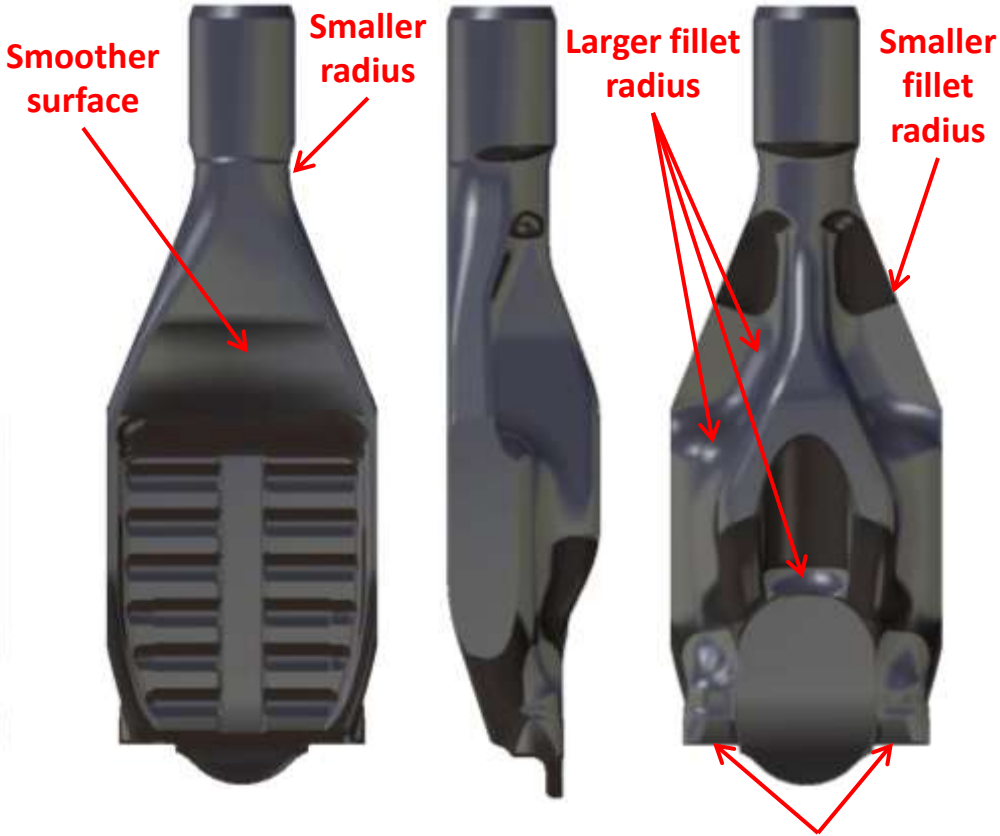

Main differences

Optimization of the control rack

Validation

2nd order mesh

Dimensioning loadcase : 2000 rpm – 128 bars

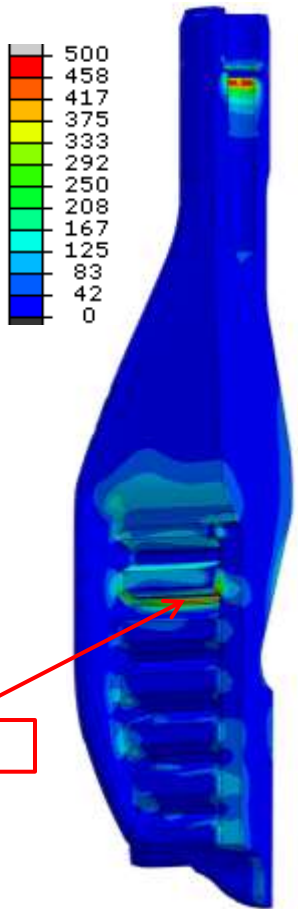

437 MPa

Max principal stress
(Scale: 0 → 500 Mpa)

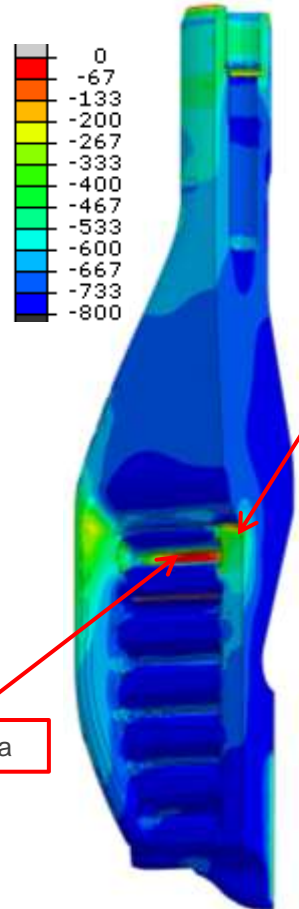

-931 MPa

Min principal stress
(Scale: -800 → 0 Mpa)

-730 MPa



Max deflection:
0.29 mm

Deflection of the
tooth: 0.18 mm

Horizontal deflection x100
(Scale: -0.1 → 0.25 mm)

Optimization of the control rack

Validation



**Fatigue validation cycle 1:
2000 rpm – 128 bars**

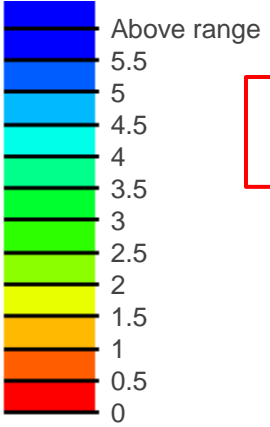
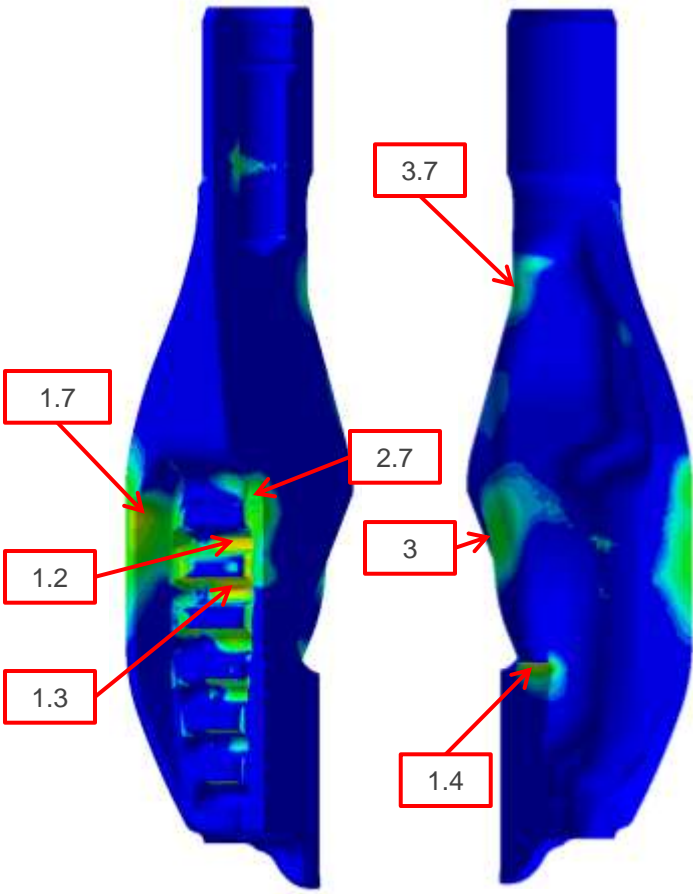

**Fatigue validation cycle 2:
6500 rpm – inertias only**

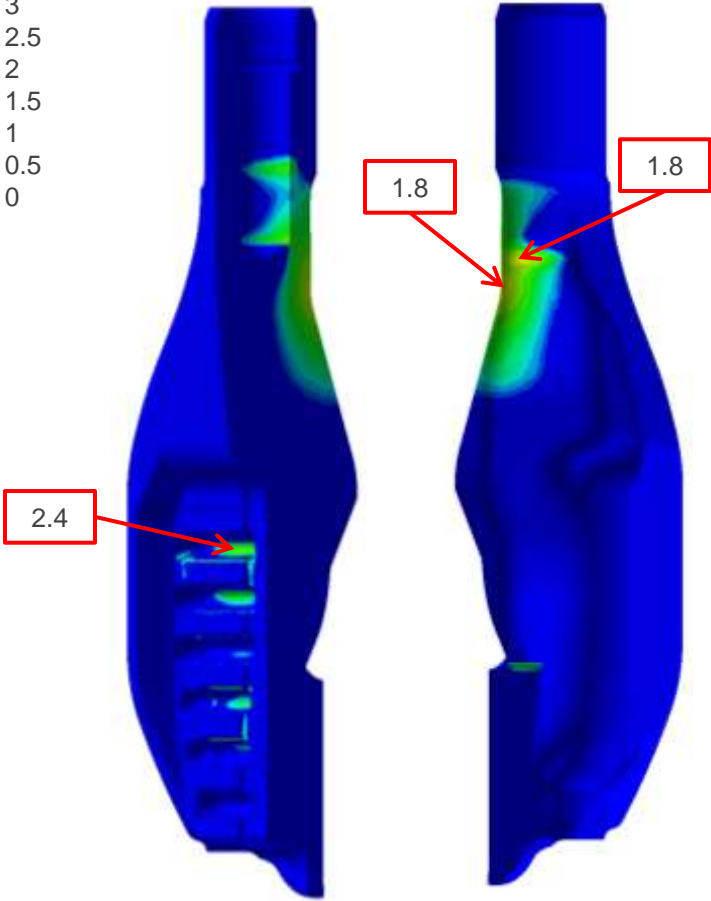

Conclusion



1350 g

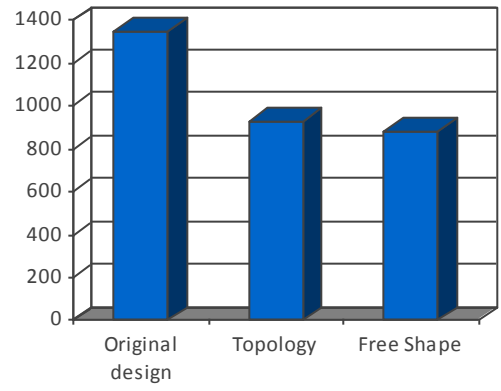

- Very efficient optimization workflow
- Reduce mass : 35% for the control rack
- Reduce time : zero prototype workflow
- Reduce costs : fully machined to forge process
- Importance of including optimization in the development process from the start

884 g



**Thank you for
your attention**



Optimization of the control rack

Topology optimization

Optimization constraint: mass < 950 g
Optimization objective: min compliance

Optimization constraint: compliance < 13000
Optimization objective: min mass

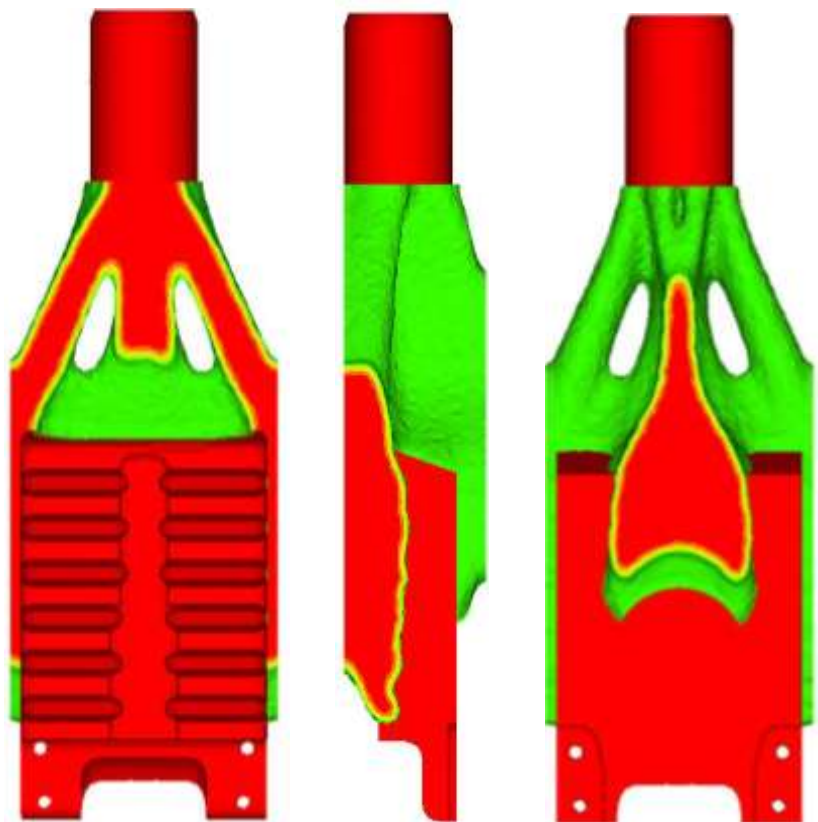

Final mass = 950 g
Final compliance = 13050

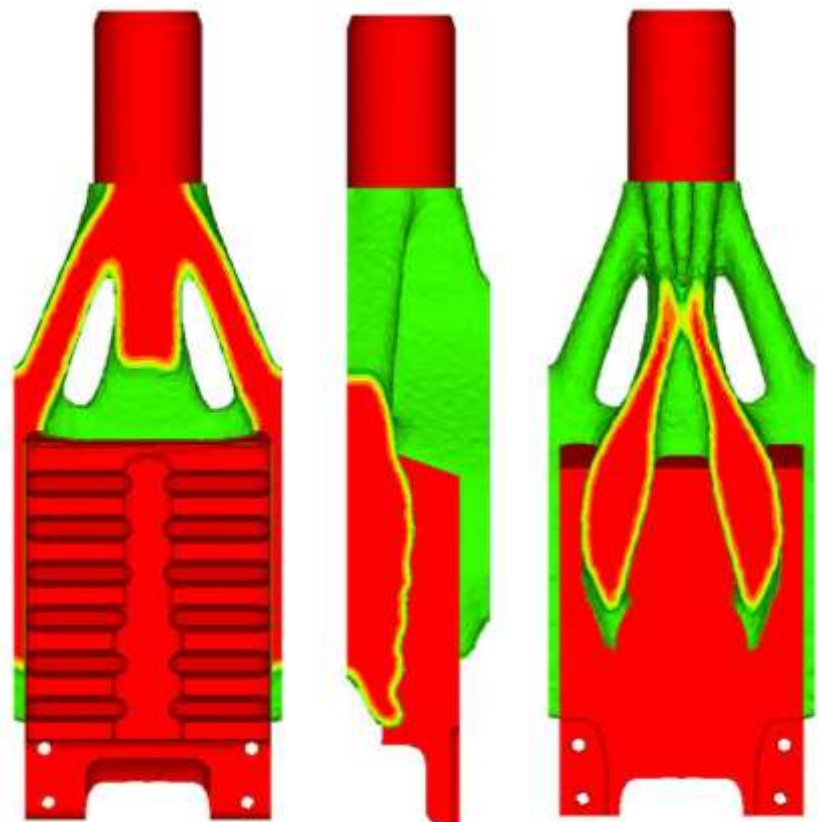

Final mass = 965 g
Final compliance = 13000